



Lenze

INTERBUS

Contents

1 Preface

1.1 Contents

1.2	Introduction	1.2-1
1.3	Comparison of industrial fieldbus systems	1.3-1
1.4	About this Communication Manual	1.4-1
1.5	Legal regulations	1.5-1

1.2 Introduction

The current situation in mechanical system engineering requires an optimisation of manufacturing costs. Therefore the modular design of machinery and systems becomes more and more popular. Individual solutions can be found more easily and at a more favourable price.

Lenze fieldbus systems in industrial applications

Optimum communication between the modules of a system is often achieved by a fieldbus system for process automation. Lenze offers the following communication modules for all common fieldbus systems:

- CAN (Lenze system bus)
- CANopen
- PROFIBUS-DP
- INTERBUS
- INTERBUS loop
- DeviceNet
- LON
- AS-i

The communication modules are especially designed for Lenze drive components and flexible use. You can use the same communication modules for Lenze servo inverters and Lenze frequency inverters.

This means for you: Easy communication.

You must only learn to know one communication system.

Handling is always the same.

You reduce your costs because you can make use of the knowledge gained once.

Trainings are only required once.

The planning time becomes shorter.

Help for your decision

The decision for a fieldbus systems depends on many different factors. The following chart will help you to find the solution for your application.

PROFIBUS-DP

Machines which use bus lengths of more than 100 meters are often equipped with INTERBUS or PROFIBUS-DP. The PROFIBUS-DP (**D**ecentralised **P**eriphery) is always used together with a PLC – and the PROFIBUS master transfers, for instance, the setpoints to the devices connected to the PROFIBUS (e.g. Lenze controllers).

The process data is transferred to the sensors and actuators at the baud rate typical for the PROFIBUS-DP (1.5 Mbit/s). Because of the data transfer method and a telegram overhead, the bus cycle time at 1.5 Mbit/s is high enough to control, for instance, conveyors. If the process data must reach sensors and actuators more quickly, the PROFIBUS can also be operated at a baud rate of max. 12 Mbit/s.

INTERBUS

INTERBUS is mainly used in big systems (many devices connected to the bus system) - for instance in the automobile industry. Its ring structure offers especially good diagnostics options. It is possible to find out which device connected to the bus is electromagnetically interfered or whether there is an earth fault or short circuit interfering the INTERBUS cable. Furthermore, INTERBUS has a baud rate of 500kbit/s which is more efficient for process data transfer than comparable bus systems. If you need extremely quick data transfer, INTERBUS can also be operated at 2 Mbit/s.

Lenze system bus (CAN)	<p>With the servo controller series 9300 Lenze has introduced the system bus based on CAN. The functions of the CANopen communication profile have been integrated into DS301. The main task of the system bus is the exchange of data between the controllers and the communication with sensors, actuators and display and operating elements without a higher level control. Furthermore it is possible to use it for demanding and time critical applications. Here the controllers are synchronised by means of a system bus.</p> <p>CAN is available at a reasonable price and is suitable for smaller machines.</p>
CANopen	<p>CANopen is a specific communication protocol according to CiA (CON in Automation). Lenze offers communication modules for control with CANopen master. These modules are compatible with the specification DS 301 V4.01.</p>
DeviceNet	<p>The American automation manufacturer Allan Bradley developed the DeviceNet fieldbus which is based on the CAN controller. This communication profile has been published in the user organisation ODVA. A large number of sensors and actuators is available. Like CANopen, DeviceNet uses controls with a DeviceNet master.</p>
LON	<p>The company Echelon (USA) developed the Local Operation Network (LON) which is mainly used for industrial applications and time-critical demands. This bus system is mainly used for automation in buildings. Every device connected to the network has its own intelligence, i.e. higher-level controls are not necessary.</p>
AS-i	<p>The lowest level of sensors and actuators is often networked by a AS-i bus (Actuator-Sensor-Interface). It is a reasonably cheap way of transferring binary signals I/O. The bus system can be handled, planned and installed easily. Two-core AS-i cables do not only transfer data but also the auxiliary energy needed for the devices connected to the AS-i bus.</p>
INTERBUS loop	<p>Similar to the AS-i, the INTERBUS loop was developed as sensor/actuator bus. Digital and analog devices can be easily connected thanks to insulation displacement connectors. The INTERBUS loop is on a lower level than the INTERBUS (remote bus). The INTERBUS loop is connected to the INTERBUS via a bus terminal.</p>

Comparison of industrial fieldbus systems

1.3 Comparison of industrial fieldbus systems

	CAN / CANOpen	DeviceNet	PROFIBUS-DP	AS-i	INTERBUS	INTERBUS loop	LON
Topology	Line with termination resistors	Line with termination resistors	Line with termination resistors	Line, tree, ring (possible)	Ring	Ring	Line (2 wire) or any other
Bus management	Multi master	Single master	Single master	Single master	Single master	Only together with INTERBUS-S; single master (bus terminal)	Multi master
Max. number of devices (master and slaves)	64	64	124 (4 segments, 3 repeaters), max. 32 per segment	124 sensors/actuators 1 master	512 slaves, 1 master	32 slaves	32385 devices distributed to 255 subnetworks with 127 devices each
Max. distance between devices without repeater	Depending on the baud rate 1 km (50 kBit/s) 25 m (1 MBit/s)	100 m (500 kBit/s) 250 m (250 kBit/s) 500 m (125 kBit/s)	1,2 km (93.75 kBit/s) 100 m (12 MBit/s)	100 m	1.5 m (local bus) 400 m (remote bus) 2.5 km (optical fibre)	10 m (max. 100 m cable length without repeater)	2 km at 78 kBit/s (twisted pair), 6.1 km at 5.48 kBit/s (optical fibre plastics)
Max. distance between devices with repeater	General length reduction Depending on the repeater used	not specified	10 km (93.75 kBit/s)	300 m (2 repeaters)	13 km (remote bus), 100 km (optical fibre)	No repeater required	Almost any Expandable by subnetworks (without repeaters)
Transfer medium	Shielded, twisted pair cable	Shielded, twisted pair cable	Shielded, twisted pair cable	Unshielded and untwisted flat pair cable	Shielded, twisted 5-wire cable Optical fibre, infrared	Unshielded, twisted pair cable	Unshielded and untwisted pair cable Radio, optical fibre, power line
Auxiliary energy supply via bus cable	Possible via additional wires in the bus cable	Possible via additional wires in the bus cable	Possible via additional wires in the bus cable	Current supply via data cable (2 to 8 A)	separately, group via bus terminal (remote bus)	Current supply via data cable (approx. 1.5 A)	Possible via additional wires in the bus cable
Baud rate	10 kBit/s - 1 MBit/s	125 kBit/s, 250 kBit/s, 500 kBit/s	9.6 kBit/s - 12 MBit/s	167 kBit/s	500 kBit/s or 2 MBit/s	500 kBit/s	78 kBit/s - 1.25 MBit/s
Update time typical (e.g. 8 devices, 4 bytes user data)	approx. 1.32 ms at 1 MBit/s (high priority)	approx. 2.64 ms at 500 kBit/s (high priority)	approx. 2.5 ms at 500 kBit/s	typically 5 ms (every 4 bits)	at least 2 ms (process data)	at least 2 ms (process data)	approx. 70 ms
Telegram length (user data)	0 to 8 bytes	0 to 8 bytes	0 to 246 bytes	4 bits	1 to 64 bytes data; up to 246 bytes parameters	1 to 64 bytes data; up to 246 bytes parameters	1 to 228 bytes data; typically approx. 11 bytes
Telegram length (total)	106 bits at 8 bytes user data	106 bits at 8 bytes user data	user data + 6 to 11 bytes	21 bits, of which: 14 bits master, 7 bits slave	user data + 6 bytes	user data + 6 bytes	max. 255 bytes, user data + 27 bytes
Bus access methods	CSMA/CA message oriented	CSMA/CA message oriented	Cyclic polling	Cyclic polling	Time grid / distributed shift register	Time grid / distributed shift register	Modified CSMA/CD
Lenze communication modules for LENZE basic devices							
• 9300 Servo Inverter and Servo PLC	on board (only parts of CANopen) CANopen 2175 (pluggable)	2175 (pluggable)	2133 (pluggable)	not available	2111 and 2113 (both pluggable)	2112 (pluggable)	2141 (pluggable)
• 8200 vector frequency inverter	Function module System bus (only parts of CANopen) E82ZAFCC010 E82ZAFCC100 or E82ZAFCC210 or pluggable 2175 (CANopen) 2171, 2172 (parts of CANopen)	Function module (in preparation) Pluggable 2175	Function module E82ZAFPC010 or 2133 (pluggable)	E82ZAFFC010 function module	Function module E82ZAFIC010 (can be integrated) or 2111 or 2113 (both pluggable)	2112 (pluggable)	2141 (pluggable)
• Frequency inverter 8200 motec	Function module System bus (only parts of CANopen) E82ZAFCC001	(in preparation)	Function module E82ZAFPC001	Function module E82ZAFFC001	Function module E82ZAFIC001 (can be integrated)	-	-
• Drive PLC	Function module System bus (only parts of CANopen) E82ZAFCC010 or 2175 (pluggable)	2175 (pluggable)	2133 (pluggable)	-	2111 and 2113 (both pluggable)	2112 (pluggable)	2141 (pluggable)
• starttec	Function module System bus (only parts of CANopen) E82ZAFCC001	(in preparation)	Function module E82ZAFPC001	Can be integrated into the basic device as variant	Function module E82ZAFIC001 (can be integrated)	-	-

About this Communication Manual

1.4 About this Communication Manual

Target group	This Manual is for all persons who plan a network for a machine and install, commission and maintain the network.
Contents	<p>This Manual only describes Lenze communication modules for a bus system. This Manual completes the Mounting Instructions coming with the device.</p> <ul style="list-style-type: none">• The features and functions of the communication modules are described in detail.• Typical applications are shown by examples.• It also contains<ul style="list-style-type: none">– safety instructions which must be observed by any means.– the most important technical data of the communication module.– versions of the Lenze devices to be used. These devices are servo inverters, frequency inverters, drive PLCs or motor starters (starttec).– notes on troubleshooting and fault elimination. <p>This Manual does not describe the software of different manufacturers. We cannot take any liability for corresponding information given in this Manual. Information about the use of the software can be obtained from the documentation for the master.</p> <p>The theoretical background is only explained if absolutely necessary to understand a function of the corresponding communication module.</p>
How to find information	<p>Every chapter is about a certain topic and gives you all necessary information.</p> <ul style="list-style-type: none">• The table of contents and the index help you to find information on a certain topic.• Descriptions and data of Lenze products (controllers, Drive PLC, Lenze geared motors, motors) are available in the corresponding catalogues, operating manuals and manuals. You can ask your nearest Lenze representative to send you the corresponding documents or download them as PDF files from the Internet.
Paper or PDF	The Manual is a looseleaf binder. Information about news and changes for our communication modules can be easily exchanged. Every page can be identified by date and version.



Note!

Current documentation and software updates for Lenze products can be found in the Internet under <http://www.Lenze.com>

1.5 Legal regulations

Labelling	Lenze fieldbus modules and function modules are unambiguously identified by their nameplates.
Manufacturer	Lenze Drive Systems GmbH, Postfach 101352, D-31763 Hameln
CE conformity	Conforms to the EC Low Voltage Directive
Application as directed	<p>Fieldbus modules or function modules</p> <ul style="list-style-type: none">• must only be operated as described in this Communication Manual and under the conditions described.• are accessory modules which are used as option for Lenze controllers and Lenze Drive PLCs. More information is given in the chapter: Technical Data.• must be connected and mounted in a way that they comply their functions without being hazardous for persons. <p>Observe all notes given in the chapter Safety information.</p> <p>Please see all notes and information on the corresponding fieldbus module or function module given in this Communication Manual. This means:</p> <ul style="list-style-type: none">• Read this part of the Communication Manual carefully before you start working on the system.• This Communication Manual must always be available while the fieldbus module or function module is in operation. <p>Any other use shall be deemed as inappropriate!</p>

Liability

The information, data, and notes in this Communication Manual met the state of the art at the time of printing. Claims on modifications referring to fieldbus modules/function modules which have already been supplied cannot be derived from the information, illustrations, and descriptions given in this Manual.

The specifications, processes, and circuitry described in this Communication Manual are for guidance only and must be adapted to your own specific application. Lenze does not take responsibility for the suitability of the process and circuit proposals.

The indications given in this Communication Manual describe the features of the product without warranting them.

Lenze does not accept any liability for damage and operating interference caused by:

- Disregarding the Communication Manual
- Unauthorized modifications to the fieldbus module or function module
- Operating faults
- Improper working on and with the fieldbus module/function module

Warranty

See Sales and Delivery Conditions of Lenze Drive Systems GmbH.

Warranty claims must be made immediately after detecting defects or faults.

The warranty is void in all cases where liability claims cannot be made.

Disposal

Material	recycle	dispose
Metal	•	-
Plastic	•	-
Assembled PCBs	-	•
Short Instructions/Operating Instructions	•	

2 Guide

2.1 Contents

Preface

1.1	Contents	1.1-1
1.2	Introduction	1.2-1
1.3	Comparison of industrial fieldbus systems	1.3-1
1.4	About this Communication Manual	1.4-1
1.5	Legal regulations	1.5-1

Safety information

3.1	Contents	3.1-1
3.2	Persons responsible for safety	3.2-1
3.3	General safety information	3.3-1
3.4	Layout of safety notes	3.4-1

2113 INTERBUS fieldbus module

7.1	Contents	7.1-1
7.2	General information	7.2-1
7.3	Technical data	7.3-1
7.3.1	General data and application conditions	7.3-1
7.3.2	Rated data	7.3-2
7.3.3	Protocol data	7.3-3
7.3.4	Communication times	7.3-4
7.3.5	Dimensions	7.3-6
7.4	Installation	7.4-1
7.4.1	Components of the fieldbus module	7.4-1
7.4.2	Mechanical installation	7.4-2
7.4.3	Electrical installation	7.4-3
7.5	Commissioning	7.5-1
7.5.1	Before switching on	7.5-1
7.5.2	Possible settings with the front switch	7.5-2
7.5.3	Possible settings with INTERBUS master	7.5-4
7.5.4	Ensure that the settings match the 2111 fieldbus module	7.5-5
7.5.5	Commissioning of 2113 fieldbus module	7.5-5
7.5.6	Prepare controller for INTERBUS operation	7.5-6
7.5.7	Controller enable via DRIVECOM	7.5-7
7.5.8	DRIVECOM compatibility	7.5-8
7.5.9	Special features when using 82XX, 8200 vector and 93XX	7.5-9
7.6	Data transfer	7.6-1
7.6.1	Process data channel configuration	7.6-2
7.6.2	Process data signals of Lenze controllers	7.6-7
7.6.3	Process data preconfiguration depending on L-C0009	7.6-24
7.6.4	Examples for the configuration of PI/PO data	7.6-26
7.6.5	Device control	7.6-28
7.6.6	DRIVECOM control	7.6-30
7.6.7	DRIVECOM profile parameters	7.6-33
7.6.8	Configuration of the parameter data channel (PCP communication)	7.6-47
7.7	Troubleshooting	7.7-1
7.7.1	Controller is inhibited	7.7-1
7.7.2	Check INTERBUS	7.7-3
7.7.3	Reset error (TRIP)	7.7-4
7.7.4	DRIVECOM error codes	7.7-5
7.8	Appendix	7.8-1
7.8.1	Code table	7.8-1
7.8.2	Parameter values of process data preconfiguration	7.8-4
7.9	Index	7.9-1

2.2 Total index

0 ... 9

2111 fieldbus module, Matching settings, 7.5-5

2111 INTERBUS fieldbus module, 5.1-1

2112 INTERBUS-Loop fieldbus module, 6.1

2113 INTERBUS fieldbus module, 7.1-1

8200 vector, Status word, 5.6-11, 7.6-12

82XX, Status word, 5.6-7, 7.6-8

93XX

- Control word, 5.6-18, 7.6-19

- Status word, 5.6-16, 7.6-17

A

Abort, 5.6-49, 7.6-50, 10.6-19

Ambient temperature, 10.3-1

Appendix, 5.8-1, 7.8-1, 10.8-1

Application as directed, 1.5-1

Application conditions, 5.3-1, 7.3-1, 10.3-1

Application range, 5.2-2, 7.2-2, 10.2-1

B

Basic insulation, 5.4-3, 7.4-3

Basic unit, Application range, 10.2-1

Baud rate, 5.4-4, 7.4-4

- Selection, 7.5-3

C

CE conformity, 1.5-1

Climatic conditions, 10.3-1

Code numbers, Access via the fieldbus module, 5.6-46, 7.6-47, 10.6-16

Code numbers / index, Conversion, 5.6-46, 7.6-47, 10.6-16

Code table, DRIVECOM, 5.8-3, 7.8-3

Codes

- 2111 fieldbus module, 5.8-1

- Controller, 5.8-2, 7.8-2

- Fieldbus module 2113, 7.8-1

- Lenze, 5.6-46, 7.6-47, 10.6-16

Commissioning, 5.5-1, 7.5-1, 10.5-1

- of the fieldbus module, 5.5-2, 7.5-5

- of the function module, 10.5-6

Communication medium, 5.3-1, 5.4-4, 7.3-1, 7.4-4

Communication time, Function module
PROFIBUS-DP, 10.3-1

Components of the fieldbus module, 5.4-1, 7.4-1

Configuration

- Process data channel, 5.6-2, 7.6-2

- Process data., 5.6-4, 7.6-4

Configuration of host and fieldbus module, 5.5-1

Conformity, 1.5-1

Connection

- from the INTERBUS, 5.4-6, 7.4-6

- to the INTERBUS, 5.4-7, 7.4-7

Control, DRIVECOM, 5.6-29, 7.6-30, 10.6-12

Control word, 5.6-3, 5.6-35, 7.6-3, 7.6-36, 10.6-3

- 8200 vector, 5.6-13, 7.6-14

- 82XX, 5.6-9, 7.6-10

- 93XX, 5.6-18, 7.6-19

Controller

- Application as directed, 1.5-1

- Labelling, 1.5-1

- Process data signals, 5.6-6, 7.6-7

Conversion formula, Lenze codes, 5.6-46, 7.6-47, 10.6-16

CRL entries, 5.6-48, 7.6-49, 10.6-18

Cycle time, 5.3-2, 7.3-4, 10.3-2

D

Data transfer, 5.6-1, 7.6-1, 10.6-1

Default setting

- of the DIP switches, 7.5-2

- Subindex 6000, 5.6-5, 7.6-5

- subindex 6001, 5.6-5, 7.6-6

Default setting , of the DIP switches, 10.5-4

Device control, 5.6-27, 7.6-28

Device control AIF-CTRL, , 7.5-3

Diagnostics, PROFIBUS-DP, 10.8-3

Dimensions, 5.3-4, 7.3-6, 10.3-3

DRIVECOM

- Control word, 5.6-35, 7.6-36

- Enable controller, 5.5-4, 7.5-7

- Error code, 5.7-5, 7.7-5

- Monitoring parameter, 5.6-33, 7.6-34

- Parameters of the DRIVECOM profile, 5.6-32, 7.6-33

- Process data description, 5.6-32, 7.6-33

- Ramps, 5.6-43, 7.6-44

- Speed / velocity channel, 5.6-41, 7.6-42

- Status word, 5.6-38, 7.6-39

DRIVECOM control, Control, 5.6-29, 7.6-30, 10.6-12

DRIVECOM compatibility, 5.5-5, 7.5-8
DRIVECOM control, , 7.5-3
DRIVECOM control word, Assembly, 5.6-36, 7.6-37
DRIVECOM status machine, 10.6-12
DRIVECOM status word, Assembly, 5.6-39, 7.6-40

E

E82ZAFIC0xx - INTERBUS function module, 10.1-1
E82ZAFPC00x3A10, Can be used with basic controller, 10.2-1
E82ZAFPC0103A10, Can be used with basic controller, 10.2-1
Electrical installation , 5.4-3, 7.4-3, 10.4-3
Error code, 5.6-34, 7.6-35
 - Index 603F, 5.6-34, 7.6-35

F

Features, 5.2-2, 7.2-2, 10.2-1
Fieldbus module 2111 INTERBUS, Matching settings, 7.5-5
FIF-CTRL, 10.6-10
Frequency setpoint, 5.6-3, 7.6-3, 10.6-3
Function module components, 10.4-1
Function module PROFIBUS-DP
 - Baud rate, 10.3-1
 - Communication time, 10.3-1
Function module system bus (CAN), Communication medium, 10.3-1

G

General data, 5.3-1, 7.3-1, 10.3-1
General information, 5.2-1, 7.2-1, 10.2-1
Get-OV, 5.6-50, 7.6-51, 10.6-19
Guide, 2.1-1

H

Hardware version, Type code, 5.2-1, 7.2-1

I

Identification, 5.2-1, 5.6-50, 7.2-1, 7.6-51, 10.2-1, 10.6-19
Identify, 5.6-50, 7.6-51, 10.6-19
Index, 5.9-1, 7.9-1, 10.9-1
 - Conversion, 5.6-46, 7.6-47, 10.6-16
Initiate, 5.6-49, 7.6-50, 10.6-18

Installation, 5.4-1, 7.4-1, 10.4-1
 - Wiring to the host, 5.4-3, 7.4-3
INTERBUS cycle time, 5.3-2, 7.3-4, 10.3-2
INTERBUS master, Possible settings, 7.5-4
INTERBUS network, Basic structure, 10.4-3
INTERBUS process data length, 5.8-1, 7.8-1

L

Labelling, Controller, 1.5-1
Layout of safety notes, 3.4-1
Legal regulations, 1.5-1
Lenze codes, 5.6-46, 7.6-47, 10.6-16
 - Conversion formula, 5.6-46, 7.6-47, 10.6-16
 - Name, 5.6-46, 7.6-47, 10.6-16
Lenze data types, 5.6-46, 7.6-47, 10.6-16
Liability, 1.5-2

M

Mains isolation, 5.4-3, 7.4-3
Manufacturer, 1.5-1
Mechanical installation , 5.4-2, 7.4-2, 10.4-2
Monitoring parameter, 5.6-33, 7.6-34
Monitoring time, Index 6003, 5.6-33, 7.6-34
Motor starter, Application range, 10.2-1

N

Network topology, Point-to-point, 5.4-4, 7.4-4

O

Operator, 3.2-1

P

Parameter data, 5.6-1, 7.6-1, 10.6-1
Parameter data channel, configuration, 5.6-46, 7.6-47, 10.6-16
Parameter data words, 7.5-3, 7.8-1
Parameter set transfer, 10.6-22
Parameter sets, 5.6-47, 7.6-48
 - Lenze, 5.6-47, 7.6-48, 10.6-17
Parameters
 - Control word (C0135), 5.6-3, 7.6-3, 10.6-3
 - DRIVECOM profile parameters, 5.6-32, 7.6-33
 - Frequency setpoint (C0046), 5.6-3, 7.6-3, 10.6-3
PCP communication, initialisation, 5.6-48, 7.6-49, 10.6-18

Total index

PCP services, 5.6-48, 7.6-49, 10.6-18

- Abort, 5.6-49, 7.6-50, 10.6-19
- Get-OV, 5.6-50, 7.6-51, 10.6-19
- Identify, 5.6-50, 7.6-51, 10.6-19
- initiate, 5.6-49, 7.6-50, 10.6-18
- Read and write, 5.6-49, 7.6-50, 10.6-19
- Status, 5.6-51, 7.6-52, 10.6-21

Personnel, Qualified, 3.2-1

PI, 5.6-2, 7.6-2, 10.6-2

PI data, Index 6000, 5.6-5, 5.6-32, 7.6-5, 7.6-33

PI/PO data configuration, Examples, 5.6-25, 7.6-26

Plug connectors

- How to use them, 10.4-8
- How to use them, Spring-loaded plug connectors, 10.4-8

PO, 5.6-2, 7.6-2, 10.6-2

PO data description, Index 6001, 5.6-5, 5.6-32, 7.6-6, 7.6-33

Preface, 1.1-1

Preparations, for drive control using the INTERBUS, 5.5-3, 7.5-6

Process data channel

- Configuration, 10.6-2
- configuration, 5.6-2, 7.6-2

Process data description, 5.6-32, 7.6-33

Process data monitoring time, 5.6-33, 7.6-34

Process data preconfiguration, Parameter values, 7.8-4

Process data signals, 5.6-6, 7.6-7

- 8200 vector, 5.6-10, 7.6-11
- 82XX, 5.6-6, 7.6-7
- 9300 Servo PLC, 5.6-19, 7.6-20
- 93XX, 5.6-14, 7.6-15
- Drive PLC, 5.6-19, 7.6-20

Process data telegram

- from the controller, 5.6-6, 7.6-7
- to the controller, 5.6-8, 7.6-9

Process data transfer, 5.6-2, 7.6-2, 10.6-2

Process data words, 7.5-2

Process data,, 5.6-1, 7.6-1, 10.6-1

- configuration, 5.6-4, 7.6-4
- Preconfiguration through L-C0009, 5.6-23, 7.6-24
- Proconfiguration, 7.8-4

Process-data configuration, 5.6-23, 7.6-24

Process-data structure, 5.6-4, 5.6-23, 7.6-4, 7.6-24

Process-input data, configuration, 10.6-4

Process-output data, 10.6-7

Processing time

- in the controller, 5.3-3, 7.3-5, 10.3-2
- in Drive PLC, 5.3-3, 7.3-5

Proconfiguration, of process data, 5.6-23, 7.6-24

PROFIBUS-DP, Diagnostics, 10.8-3

Program

- Program different from SYSSWT, 5.5-2
- SYSSWT, 5.5-1

Protocol data, 5.3-1, 7.3-3, 10.3-1

R

Ramps, 5.6-43, 7.6-44

Rated data, 5.3-1, 7.3-2, 10.3-1

Read and write, 5.6-49, 7.6-50, 10.6-19

S

Safety information, 3.1-1

- General, 3.3-1

Services, PCP, 5.6-48, 7.6-49, 10.6-18

Setpoint source, 5.6-3, 7.6-3, 10.6-3

Settings

- with INTERBUS master, 7.5-4
- with the front switch, 7.5-2, 10.5-3

Software version, Type code, 5.2-1, 7.2-1

Speed / velocity channel, 5.6-41, 7.6-42

Status, 5.6-51, 7.6-52, 10.6-21

Status display, 10.5-4

Status word, 5.6-38, 7.6-39

- 93XX, 5.6-16, 7.6-17

Step-by-step commissioning, 10.5-2

Switch, Possible settings, 7.5-2, 10.5-3

Switch position, 7.8-1

SYSSWT, 5.5-1

System bus (CAN), Technical data, Communication times, 5.3-2, 7.3-4, 10.3-2

T

Technical data, 5.3-1, 7.3-1, 10.3-1

Total index, 2.2-1

TRIP, Error reset, 5.7-4, 7.7-4

Troubleshooting, 5.7-1, 7.7-1, 10.7-1

Type code, 5.2-1, 7.2-1

Type of protection, 10.3-1

U

Use, as directed, 1.5-1

V

Validity of the Instructions, 10.2-1

Value range, 5.6-46, 7.6-47, 10.6-16

Vorwort, 9.1

W

Warranty, 1.5-2

Waste disposal, 1.5-2

Wiring, to a host, 5.4-3, 7.4-3

Wiring according to EMC, 4.1

Contents

3 Safety information

3.1 Contents

3.2	Persons responsible for safety	3.2-1
3.3	General safety information	3.3-1
3.4	Layout of safety notes	3.4-1

3.2 Persons responsible for safety

Operator

An operator is any natural or legal person who uses the drive system or on behalf of whom the drive system is used.

The operator and his safety personnel are obliged

- to ensure the compliance with all relevant regulations, instructions and legislation.
- to ensure that only skilled personnel works on and with the 2102IB fieldbus module.
- to ensure that the personnel has the Operating Instructions available for all corresponding works.
- to ensure that all unqualified personnel are prohibited from working on and with the drive system.

Qualified personnel

Qualified personnel are persons who - because of their education, experience, instructions, and knowledge about corresponding standards and regulations, rules for the prevention of accidents, and operating conditions - are authorized by the person responsible for the safety of the plant to perform the required actions and who are able to recognize potential hazards.

(Definition for qualified personnel to VDE 105 or IEC 364)





3.3 General safety information

- These safety notes do not claim to be complete. In case of questions and problems please contact your Lenze representative.
- At the time of delivery the communication module meets the state of the art and ensures basically safe operation.
- The indications given in these Operating Instructions refer to the stated hardware and software versions of the communication modules.
- The communication module is a source of danger if:
 - unqualified personnel works on and with the communication module
 - the communication module is used inappropriately.
- The specifications, processes, and circuitry described in these Operating Instructions are for guidance only and must be adapted to your own specific application.
- Ensure by appropriate measures that neither personal injury nor damage to property may occur in the event of failure of the communication module.
- The drive system must only be operated when no faults occur.
- Retrofittings and modifications of the communication module are prohibited. Lenze must be contacted in all cases.
- The communication module is electrical equipment intended for use in industrial high-power plants. The communication module must be tightly screwed to the corresponding controller during operation. In addition, all measures described in the Operating Instructions of the controller used must be taken. Example: Fasten covers to ensure protection against contact.

3.4 Layout of safety notes

All safety information given in these Instructions have got the same layout:

Pictograph (indicates the type of danger)
Signal word! (indicates the severity of danger)
Note (describes the danger and explains how to avoid it)

Pictograph	Signal word		Possible consequences if the safety information are disregarded
	Signal word	Meaning	
 Dangerous electrical voltage	Danger!	Impending danger for persons	Death or most severe injuries
	Warning!	Possible, very dangerous situation for persons	Death or most severe injuries
 General danger	Caution!	Possible, dangerous situation for persons	Injuries
	Stop!	Possible material damage	Damage of the drive system or its surroundings
	Note!	Useful note or tip If you observe it, handling of the drive system will be easier.	

4 Wiring according to EMC



Note!

This topic has not been described yet.
You will be informed as soon as this chapter will be available.

7 2113 INTERBUS fieldbus module

7.1 Contents

7.2	General information	7.2-1
7.3	Technical data	7.3-1
7.3.1	General data and application conditions	7.3-1
7.3.2	Rated data	7.3-2
7.3.3	Protocol data	7.3-3
7.3.4	Communication times	7.3-4
7.3.5	Dimensions	7.3-6
7.4	Installation	7.4-1
7.4.1	Components of the fieldbus module	7.4-1
7.4.2	Mechanical installation	7.4-2
7.4.3	Electrical installation	7.4-3
7.5	Commissioning	7.5-1
7.5.1	Before switching on	7.5-1
7.5.2	Possible settings with the front switch	7.5-2
7.5.3	Possible settings with INTERBUS master	7.5-4
7.5.4	Ensure that the settings match the 2111 fieldbus module	7.5-5
7.5.5	Commissioning of 2113 fieldbus module	7.5-5
7.5.6	Prepare controller for INTERBUS operation	7.5-6
7.5.7	Controller enable via DRIVECOM	7.5-7
7.5.8	DRIVECOM compatibility	7.5-8
7.5.9	Special features when using 82XX, 8200 vector and 93XX	7.5-9
7.6	Data transfer	7.6-1
7.6.1	Process data channel configuration	7.6-2
7.6.2	Process data signals of Lenze controllers	7.6-7
7.6.3	Process data preconfiguration depending on L-C0009	7.6-24
7.6.4	Examples for the configuration of PI/PO data	7.6-26
7.6.5	Device control	7.6-28
7.6.6	DRIVECOM control	7.6-30
7.6.7	DRIVECOM profile parameters	7.6-33
7.6.8	Configuration of the parameter data channel (PCP communication)	7.6-47
7.7	Troubleshooting	7.7-1
7.7.1	Controller is inhibited	7.7-1
7.7.2	Check INTERBUS	7.7-3
7.7.3	Reset error (TRIP)	7.7-4
7.7.4	DRIVECOM error codes	7.7-5
7.8	Appendix	7.8-1
7.8.1	Code table	7.8-1
7.8.2	Parameter values of process data preconfiguration	7.8-4
7.9	Index	7.9-1

7.2 General information

Validity of the Instructions

These Instructions are only valid

- for fieldbus modules as of nameplate data 2113IB.1x.1x.
- together with the documentation for the basic devices permitted for the application.

Identification

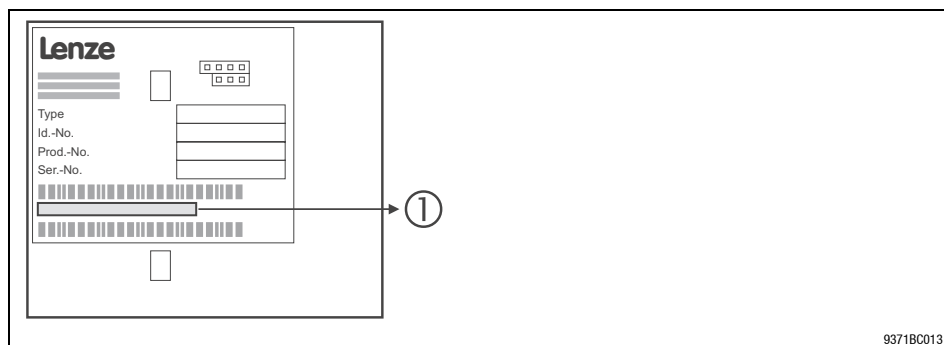

Type code

33.2113IB

①

1x

1x

Type series INTERBUS

Hardware version

Software version

Variant

Application range

The fieldbus module can be used together with devices with the following nameplate data:

820X	E./C.	2x.	1x.	Vxxx	(8201 - 8204)
821X	E./C.	2x.	2x.	Vxxx	(8211 - 8218)
822X	E.	1x.	1x.	Vxxx	(8221 - 8227)
824X	E./C.	1x.	1x.	Vxxx	(8241 - 8246)
82EVxxxxBxxxXX		Vx	13		(8200 vector)
82CVxxxxBxxxXX		Vx	13		(8200 vector, Cold plate)
EPL 10200	I./T.	1x	1x		(Drive PLC)
93XX	Ex/Cx	2x	1x		(9321 - 9332)
93XX	E.C. I./T.	2x	1x		(Servo PLC 9300)

Type

Design:

Ex = Built-in unit IP20

Cx = Cold plate

I = Servo PLC

xK = Cam profiler

xP = Positioning controller

xR = Register controller

xS = Servo inverter

Hardware version

Software version

Variant

Explanation

Features

The fieldbus module 2113 INTERBUS is

- an attachable intelligent additional module with a 16-bit micro-processor.
- compatible with the Lenze fieldbus module 2111 INTERBUS.

Benefits of the fieldbus module 2113 INTERBUS:

- Communication of 82XX, 8200 vector, 93XX controllers and 9300 servo PLC via INTERBUS.
- Communication of Lenze Drive PLCs via INTERBUS.
- Bus connection via remote bus according to standard RS485.
- Access to all Lenze parameters.
- Because of its DIP switch on the front:
 - Choice between DRIVECOM drive profile 21 or device control AIF-CTRL.
 - Change of baud rate.
 - Change of number of process data words (PD)
 - Change of number of parameter data words (PCD).

Technical data

7.3

General data and application conditions

7.3.1

7.3 Technical data

7.3.1 General data and application conditions

Field	Values
Order number	EMC 2113IB
Communication media	RS485
Network topology	Ring
INTERBUS participant	Slave
Communication profile	PCP 2.0
Drive profile	DRIVECOM profile 21
Baud rate	<ul style="list-style-type: none"> • 500 kBit/s • 2 MBit/s
Ambient temperature	during operation: 0 °C to 55 °C during transport: -25 °C to 70 °C during storage -25 °C to 60 °C
Permissible humidity	Class 3K3 to EN 50178 (without condensation, average relative humidity 85%)
Degree of pollution	VDE0110, part 2, pollution degree 2
Enclosure	IP 20
Voltage supply (internal / external), see  7.4-5	External supply via separate power supply unit (+24 V DC ±10 %, max. 120 mA)

7.3.2 Rated data

Insulation voltages between incoming bus and ...	Rated insulation voltage	Type of insulation
<ul style="list-style-type: none"> • Reference earth / PE • External supply (terminal 39/59) 	50 V AC	Mains isolation
	50 V AC	Mains isolation
<ul style="list-style-type: none"> • Power stage <ul style="list-style-type: none"> – 820X / 821X – 822X / 8200 vector – 93XX 	270 V AC	Basic insulation
	270 V AC	Double insulation
	270 V AC	Double insulation
<ul style="list-style-type: none"> • Control terminals <ul style="list-style-type: none"> – 820X / 8200 vector (with internal supply) – 8200 vector (with external supply) – 821X – 822X – 93XX 	0 V AC	No mains isolation
	100 V AC	Basic insulation
	50 V AC	Mains isolation
	270 V AC	Basic insulation
	270 V AC	Basic insulation
<ul style="list-style-type: none"> • Outgoing bus (OUT) 	50 V AC	Mains isolation

Insulation voltages between outgoing bus and ...	Rated insulation voltage	Type of insulation
<ul style="list-style-type: none"> • Earth reference / PE • External supply (terminal 39/59) 	50 V AC	Mains isolation
	0 V AC	No mains isolation
<ul style="list-style-type: none"> • Power stage <ul style="list-style-type: none"> – 820X / 821X – 822X / 8200 vector – 93XX 	270 V AC	Basic insulation
	270 V AC	Double insulation
	270 V AC	Double insulation
<ul style="list-style-type: none"> • Control terminals <ul style="list-style-type: none"> – 820X / 8200 vector (with internal supply) – 8200 vector (with external supply) – 821X – 822X – 93XX 	0 V AC	No mains isolation
	100 V AC	Basic insulation
	50 V AC	Mains isolation
	270 V AC	Basic insulation
	270 V AC	Basic insulation
<ul style="list-style-type: none"> • Input bus (IN) 	50 V AC	Mains isolation

7.3.3 Protocol data

Field	Values
Maximum number of controllers	Dependent on INTERBUS master (e.g. Phoenix Contact G4-Master). For the following data, always the smaller value applies dependent on the fact, whether PCP communication is available or not: <ul style="list-style-type: none"> • With PCP communication: 62 or • Without PCP communication: 256/number PD
Process data words (PD)	1 ... 10 (selectable) Default setting: 2 words
Parameter data words (PCP)	0, 1, 2, 4 Default setting: 1 word
Maximum number of data words	As a maximum the data word sum (PD + PCP) is to amount to 10 words.
INTERBUS ID (module ID)	Module ID for set length
	3 _{dec} = 03 _{hex} PCP 0 words
	227 _{dec} = E3 _{hex} PCP 1 word
	224 _{dec} = E0 _{hex} PCP 2 words
	225 _{dec} = E1 _{hex} PCP 4 words
Maximum PDU length	64 byte
Supported PCP services	Initiate, abort, status, identify, Get-OV-long, read, write

7.3.4 Communication times

7.3.4.1 Cycle time

The cycle time of a communication system is the time needed to exchange all process data (▣ 7.6-7) between the INTERBUS master and the devices connected to the bus.

It depends on the communication system data and is calculated as follows (example: baud rate of 500 kbit/s):

$$t_{\text{cycl}} = (n + 48 + 3 \times \text{BK}) \times 3.35 \times 10^{-3} + 0.24 \times L + 0.2$$

t_{cycl}	Cycle time in [ms]
n	Sum of all data bit in the INTERBUS ring
BT	Number of bus terminals
L	Length of remote bus cable in [km]

Fig. 7.3-1 is shows the ratio between cycle time and number of connected controllers.

The indicated values refer to the connection of Lenze controllers (e. g. 2XX) with 48 data bits (1 parameter data word + 2 process data words, see (▣ 7.3-3).

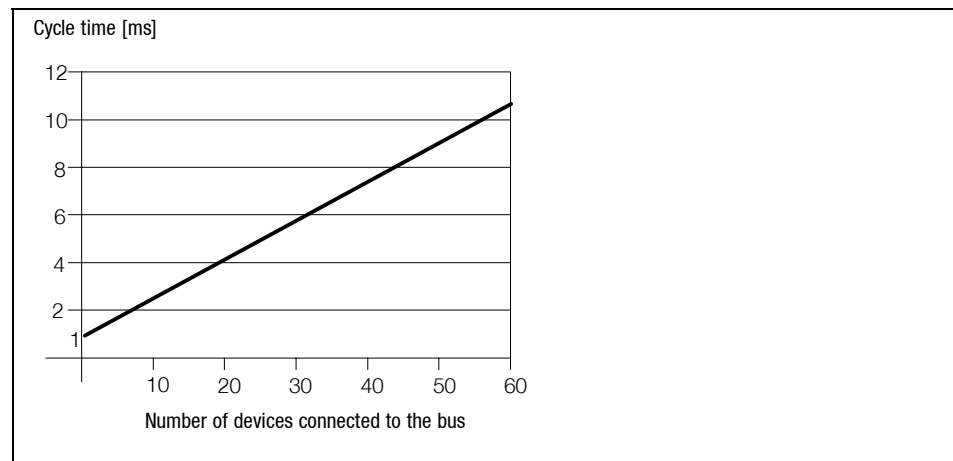

Fig. 7.3-1 INTERBUS cycle time for controllers

7.3.4.2 Processing time in the controller

The processing time of the controller is added to the INTERBUS cycle time.

The processing time of the controller depends on the series and version:

Processing time 820X

For the 820X series several processing steps are required. These steps are processed cyclically.

A processing cycle consists of:

- Writing of control word or setpoint, if the value has changed
- Alternating reading of status word and actual value
- Processing of PCP parameter access, if there is a service.



Note!

A change of the setpoint signal results in writing the control word.

If the time tolerances caused by cyclic reading of the status word/actual value are too large, the alternating reading of the status word and the actual value can be suppressed. This is controlled by bit 15 (PE inhibit) of the DRIVECOM control word: (☞ 7.6-36).

A suppression of the processing of parameter access is not necessary, since this is controlled by the user.

In the following table you will find a list of the processing times:

Processing step	Max. processing time [ms]	Processing tolerance [ms]	Additional parameter [ms]
Parameter	70	-8	-
Setpoint	35	-8	180
Control word	35	-8	180
Actual value	35	-8	180
Status word	35	-8	180
Setpoint + control word	70	-16	180
Setpoint + control word + actual value + status word	140	-32	180

Processing time 821X / 8200 vector / 822X

The parameter data (transmission via PCP channel) and process data are independent of each other.

- Parameter data (PCP): approx. 30 ms + 20 ms tolerance
- Process data (PD): approx. 3 ms + 2 ms tolerance

Processing time 9300 servo inverter

The parameter data (transmission via PCP channel) and process data are independent of each other.

- Parameter data (PCP): approx. 30 ms + 20 ms tolerance
- Process data (PD): approx. 2 ms + 1 ms tolerance

Processing time Drive PLC / 9300 Servo PLC

- Parameter data (PCP): 30 ms + 20 ms tolerance
- Process data (PD): depending on process image

7.3.5 Dimensions

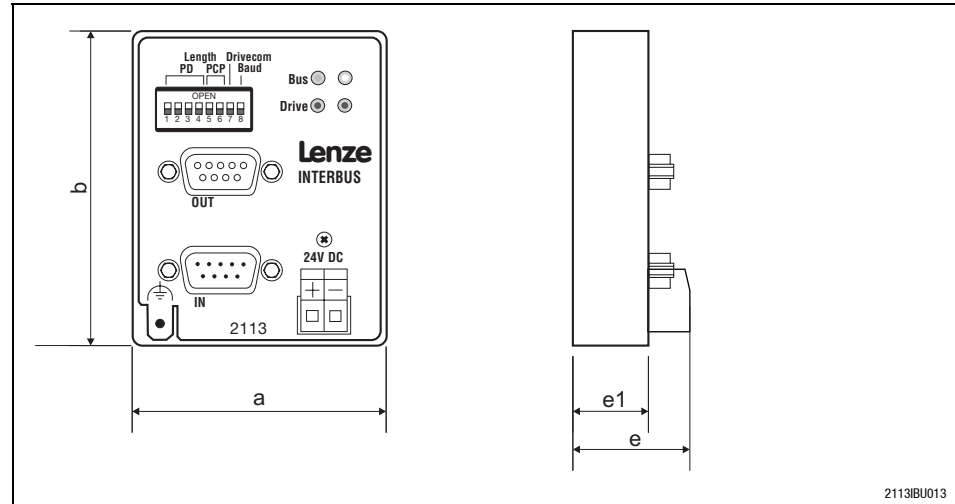

2113IBU013

a	61 mm
b	75 mm
e	28 mm
e1	18 mm

Installation

Components of the fieldbus module

7.4 Installation

7.4.1 Components of the fieldbus module

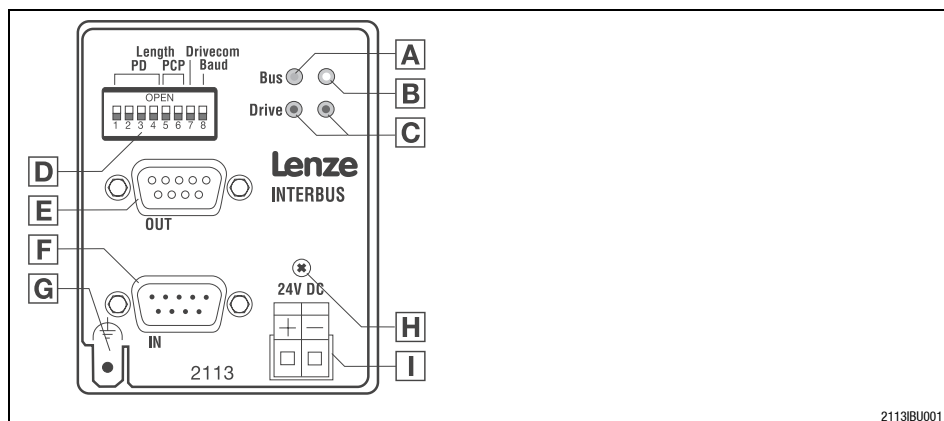

Fig. 7.4-1 Components of the fieldbus module

Pos	LED status	Explanation
A	Green bus LED (voltage supply)	
	ON	The fieldbus module is supplied with voltage and is connected to the drive controller.
	OFF	The fieldbus module is not supplied with voltage. The drive controller or external voltage supply is switched off.
B	Yellow bus LED (communication)	
	ON	Fieldbus module is initialised, inactive INTERBUS communication of the master
	OFF	Fieldbus module is not initialised yet
C	Red and green drive LED indicate the operating mode of the drive controller 82XX or 93XX (see the Operating Instructions of the drive controller)	
	BLINKING	The fieldbus module is supplied with voltage, but it is not connected to the drive controller, because <ul style="list-style-type: none"> • the fieldbus module was not plugged on the drive controller correctly • the data transfer of/to the drive controller is not possible (e. g. the drive controller is in the initialisation phase).
	BLINKING	Active INTERBUS communication <ul style="list-style-type: none"> • SLOW (1 Hz): process data and PCP communication. • FAST (4 Hz): only process data • VERY FAST (8 Hz) <ul style="list-style-type: none"> – indicates inadmissible settings: <ul style="list-style-type: none"> Data word sum: $PD + PCP > 10$ or number of process data words: $PD = 0$. – The fieldbus module goes on working internally with the following values: $PD = 2$ and $PCP = 1$
E	INTERBUS output (OUT), Sub-D socket connector, 9-pole 7.4-7	
F	INTERBUS input (IN), Sub-D plug connector, 9-pole 7.4-6	
G	PE connection see note	
H	Fixing screw	
I	Plug connector, connection for external voltage supply 7.4-4	



Note!

Only for 820X and 821X: If required use an additional PE screen cable which avoids EMC-related communication interference in surroundings with interferences.

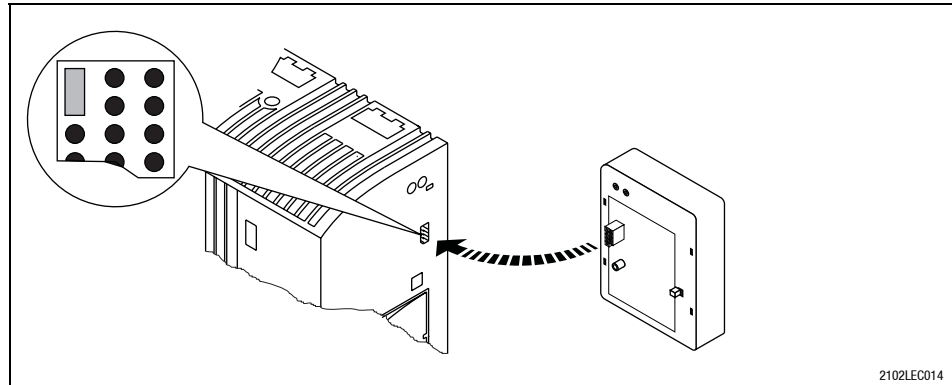
7.4.2 Mechanical installation

- Plug the fieldbus module onto the basic device (here: 8200 vector).
- Fasten the fieldbus module with the fixing screw onto the basic device to ensure a good PE connection.

**Note!**

For the internal supply of the fieldbus module through the 8200 vector frequency inverter the interface of the jumper must be adapted (see illustration above). Please observe the notes  7.4-5.

7.4.3 Electrical installation

Wiring to the INTERBUS master



Note!

An additional mains isolation is required, if

- an 820X or 821X is connected to an INTERBUS master **and**
- a safe mains isolation (double basic insulation) is required according to VDE 0160.

Use e.g. a bus terminal or an interface module for the INTERBUS master with an additional mains isolation (see the corresponding information of the manufacturer).

The incoming bus (IN) is isolated from the supply voltage and the outgoing bus (OUT).

The supply voltage has the same potential as the outgoing data bus (OUT).

- The bus system must be designed as a ring.
- Go-and-return lines are both in the same bus cable.
- The ring connects the INTERBUS master with all devices connected to the bus.

Wiring example

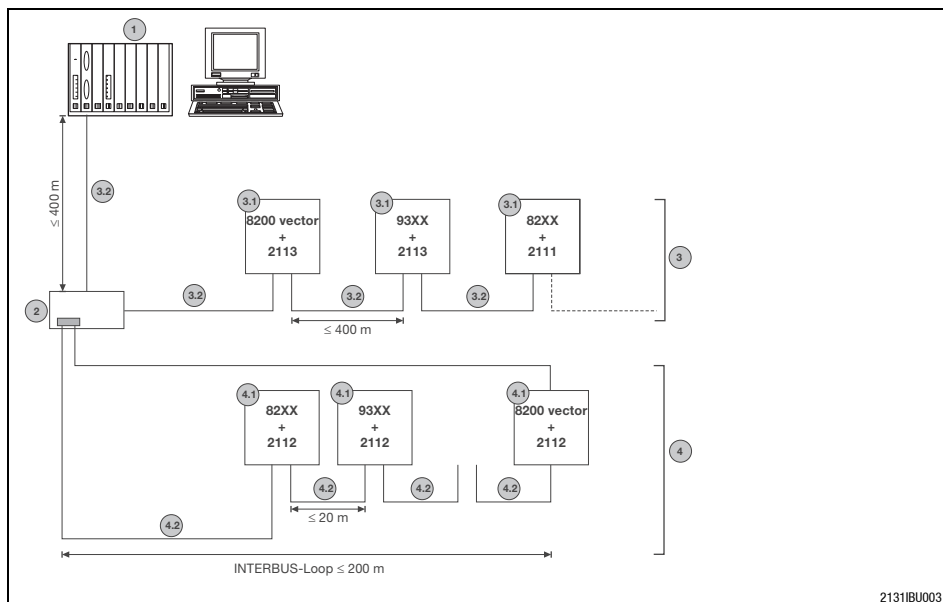

Fig. 7.4-2 Wiring example, INTERBUS (baud rate 500 kbit/s)

Pos.	Element	Explanation
1	INTERBUS master with interface module	The bus system is a master-slave system, i.e. an INTERBUS master is connected to several field devices (slaves).
2	INTERBUS loop bus terminal	The bus terminal connects a long distance bus to a peripheral bus.
3	Remote bus Fig. 5.4-2 Pos. 3	The following connections are possible with remote buses: <ul style="list-style-type: none"> • Connections between INTERBUS master interface module and first bus terminal or first 2113 fieldbus module. • Connection between bus terminal and 2113 fieldbus module • Connection between two 2113 fieldbus modules
3.1	Long distance bus module	Bus participant in the long distance bus; e.g. Lenze controller with INTERBUS module (slave). Networking does not require bus terminals.
3.2	Remote bus cable	Connects the INTERBUS master interface module with the bus terminal and/or the long distance bus modules.
4	INTERBUS loop, peripheral bus Fig. 5.4-2 Pos. 4	Connection in a peripheral-bus station A peripheral-bus station consists of: <ul style="list-style-type: none"> • a bus terminal (Fig. 5.4-2 pos. 2) • up to eight peripheral bus modules (Fig. 5.4-2 pos. 3)
4.1	INTERBUS loop module	Bus participant in the INTERBUS loop; e.g. Lenze controller with INTERBUS loop module 2112
4.2	INTERBUS loop cable	Connection within the loop

Features:		
Communication medium	RS485	
Network topology	Ring	
Maximum number of controllers	Dependent on INTERBUS master (e.g. Phoenix Contact G4-Master). For the following data, always the smaller value applies dependent on the fact, whether PCP communication is available or not: <ul style="list-style-type: none"> • With PCP communication: 62 or • Without PCP communication: 256/number PD 	
Baud rate / cable length	Baud rate	Maximum cable length between neighbouring participants
	500 kBit/s	400 m
	2 MBit/s	150 m

Specification of INTERBUS remote bus cable	
Cable type	Yard goods: IBS RBC Meter-T, order No. 28 06 28 6 (Fa. Phoenix Contact)
Number of conductors	3 x 2, paired with common shielding
Conductor cross-section	> 0.2 mm ²
DC cable resistance	< 96 Ω/km
Impedance, characteristic	120 Ω ± 20 % (f = 64 kHz) 100 Ω ± 15 % (f > 1 MHz)
Capacitance per unit length	< 60 nF/km (f = 800 Hz)

External DC voltage supply





If necessary, supply the 2113 fieldbus module with a separate supply voltage 24 V DC via the two-pole plug connector ±10 %.

Plug connector	Name	Explanation
+	Vcc24	External supply 24 V DC ± 10 %, 120 mA
-	GND24	Reference potential for external voltage supply

Use a separate power supply unit in each control cabinet.

Controller	External voltage supply
820X	Always required
821X / 822X / 824X and 93XX	Only necessary if the mains which supply the corresponding controllers is to be switched off but the communication must not be interrupted.
8200 vector	See information in "internal DC voltage supply"

Connection terminals

Electrical connection	Plug connector with threaded terminal end
Possible connections	 rigid: 1.5 mm ² (AWG 16)
	 flexible: without wire crimp cap 1.5 mm ² (AWG 16)
	 with wire crimp cap, without plastic sleeve 1.5 mm ² (AWG 16)
	 with wire crimp cap, with plastic sleeve 1.5 mm ² (AWG 16)
Tightening torque	0.5 ... 0.6 Nm (4.4 ... 5.3 lb-in)
Bare end	6 mm

Internal DC voltage supply



Note!

Basic devices with extended AIF interface opening (8200 vector front) can be internally supplied. The part of the drawing highlighted in grey shows the jumper position.

- In the delivery state of the frequency inverter these are not internally supplied.
- For internal voltage supply, put the jumper in the position indicated below.

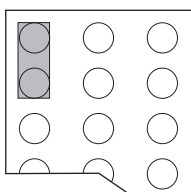
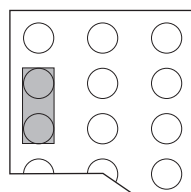
Lenze setting only external voltage supply	Internal voltage supply
	

7.4.3.1 Connection from the INTERBUS

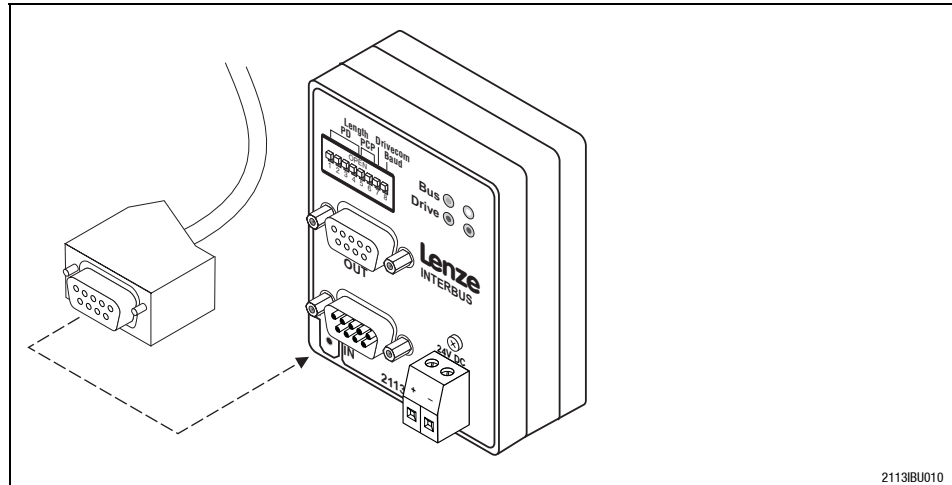

2113IBU010



2113IBU012

Sub-D pin connector (IN)			
Pin	Name	Input/output	Explanation
1	DO1	Input	RS485: DO1 not inverted
2	DI1	Output	RS485: DI1 not inverted
3	GND		Reference potential
4	free		
5	Vcc5		5 V DC
6	/DO1	Input	RS485: DO1 inverted
7	/DI1	Output	RS485: DI1 inverted
8	Vcc5		5 V DC
9	free		

Tab. 7.4-1 Pin assignment of the Sub-D pin connector (IN)

7.4.3.2 Connection to the INTERBUS

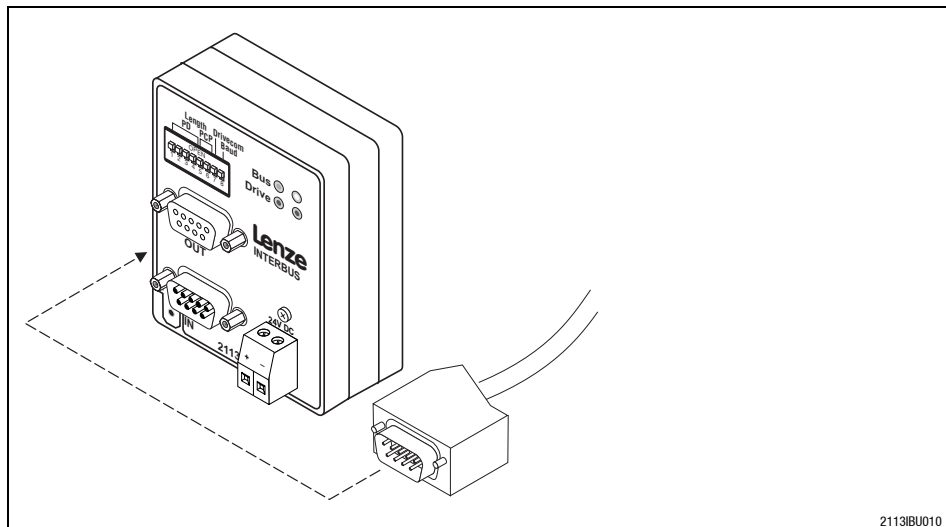

2113IBU010



2113IBU011

Sub-D socket connector (OUT)			
Pin	Name	Input/output	Explanation
1	DO2	Output	RS485: DO2 not inverted
2	DI2	Input	RS485: DI2 not inverted
3	GND		Reference potential
4			
5	Vcc5	Output	5 V DC
6	/DO2	Output	RS485: DO2 inverted
7	/DI2	Input	RS485: DI2 inverted
8	Vcc5		5 V DC
9	RBST	Message input	The assignment of the Sub-D socket connector (OUT) with a Sub-D plug is indicated.

Tab. 7.4-2 Pin assignment of the Sub-D socket connector (OUT)

7.5 Commissioning

7.5.1 Before switching on



Stop!

Before switching on the mains voltage, check the wiring for completeness, earth fault and short circuit.



Note!

Do not change the switch-on sequence!

7.5.2 Possible settings with the front switch

**Note!****Switches S1 ... S7**

- All in OFF position:
The configurations set for the codes L-1910, L-1911 and L-1912 get active with switching on.
- One or several switches in ON position:
All switch positions are valid!
The following must be set:
 - Number of process data words (PD),
 - Number of parameter data words (PCP) and
 - Device control AIF-CTRL / DRIVECOM control

The Lenze setting of the switches (S1 - S8) is **OFF** .

Switch off the voltage supply of the fieldbus module and afterwards on again, in order to activate changed settings.

As a maximum the data word sum (PD + PCP) is to amount to 10 words.

Please note that only the switch combinations listed in the following tables represent defined states. If the settings are unacceptable, the yellow bus LED at the front of the fieldbus module will start blinking (8kHz).

Setting number of process data words (PD)

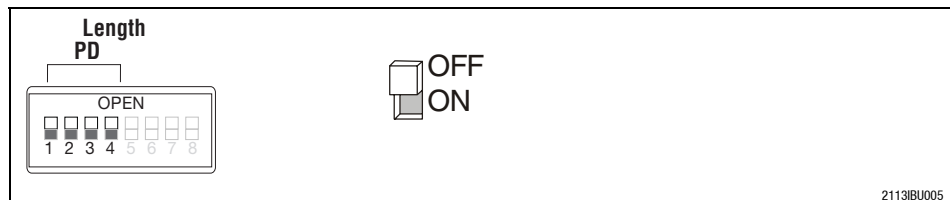

2113IBU005

PD	S1	S2	S3	S4	Maximum number of parameter data words (PCP)
1	OFF	OFF	OFF	ON	4
2	OFF	OFF	ON	OFF	
3	OFF	OFF	ON	ON	
4	OFF	ON	OFF	OFF	
5	OFF	ON	OFF	ON	
6	OFF	ON	ON	OFF	
7	OFF	ON	ON	ON	2
8	ON	OFF	OFF	OFF	
9	ON	OFF	OFF	ON	1
10	ON	OFF	ON	OFF	0

**Note!**

Impermissible settings are indicated by the yellow bus LED (communication). (7.4-1) .

Display of the current switch position S1 ... S4 for number of process data words (PD) is possible because of code L-C1915.

Commissioning

7.5

Possible settings with the front switch

7.5.2

Setting number of parameter data words (PCP)

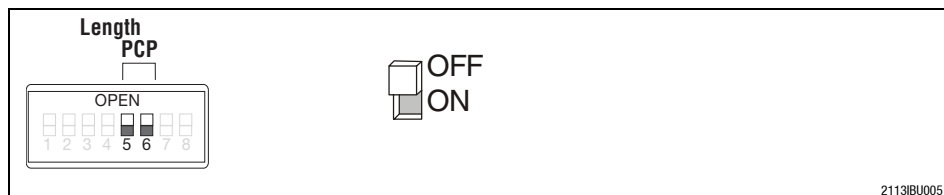

2113IBU005

PCP	S5	S6	Maximum number of process data words (PD)	ID code
0	OFF	OFF	10	3 _{hex}
1	OFF	ON	9	E3 _{hex}
2	ON	OFF	8	E0 _{hex}
4	ON	ON	6	E1 _{hex}



Note!

Impermissible settings are indicated by the yellow bus LED (communication) (7.4-1).

Display of the current switch position S5/S6 for number of parameter data words (PCP) is possible because of code L-1917.

Select AIF-CTRL or DRIVECOM control

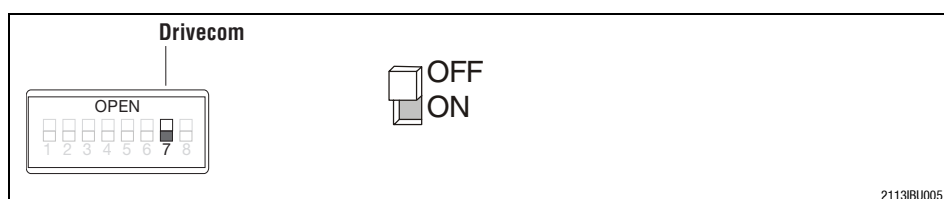

2113IBU005

S7	Explanation
OFF	with AIF-CTRL control
ON	with DRIVECOM control



Note!

Display of the current switch position S7 is possible because of code L-C1916.

Select baud rate

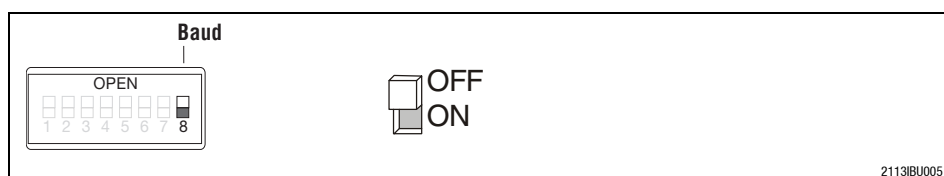

2113IBU005

S8	Baud rate	Maximum cable length between neighboring participants
OFF	500 kBit/s	400 m
ON	2 MBit/s	150 m



Note!

The baud rate can only be set through switch S8.

7.5.3 Possible settings with INTERBUS master

**Note!**

Conditions for setting through the INTERBUS master:

Switch S1 ... S7 = OFF

- The configurations set for the codes L-1910, L-1911 and L-1912 get active with switching on.
- The settings can be changed.
- Switch off the voltage supply of the fieldbus module and afterwards on again, in order to activate changed settings.

As a maximum the data word sum (PD + PCP) is to amount to 10 words.

Index detection: 24575 - Lenze code number (L-C xxxx)

Impermissible settings are indicated by the yellow bus LED (communication) (☐ 7.4-1).

Code	Values	Explanation	
L-C1910	2 ... 20 (1 ... 10 words)	Number of process data bytes (2 Process data bytes = 1 Process data word)	
L-C1911	0: Device control AIF-CTRL 1: DRIVECOM control	Operation with device control AIF-CTRL or operation with DRIVECOM-Profil 21	
L-C1912	Number of parameter data words (PCP)	Number of parameter data words (PCP)	
	0		3 _{hex}
	1		E3 _{hex}
	2		E0 _{hex}
	4		E1 _{hex}

Display codes

Code	Explanation
L-C1915	Display of the current switch positions S1 ... S4 for number of process data words
L-C1916	Display of the current position of switch S7.
L-C1917	Display of current switch positions S5/S6 for number of parameter data words (PCP).

Commissioning

Ensure that the settings match the 2111 fieldbus module

7.5.4 Ensure that the settings match the 2111 fieldbus module

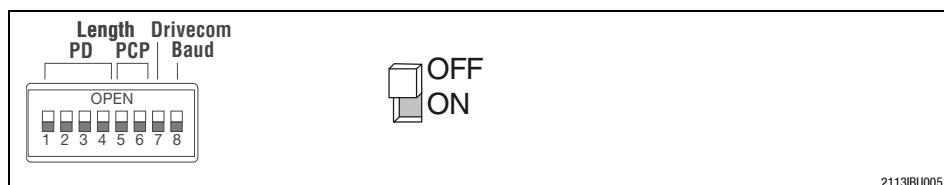

S1 ... S8	Explanation
OFF (Lenze setting)	The response is the same as of the Lenze fieldbus module "2111 INTERBUS", if the Lenze setting for the switches (S1 - S7 = OFF) <u>and</u> codes L-C1910 = 4, L-C1911 = 1 and L-C1912 = 1 remain unchanged.

7.5.5 Commissioning of 2113 fieldbus module

1. The fieldbus module must be attached to the controller (☞ 7.4-2).
2. The controller and if available the separate voltage supply for the 2113 fieldbus module must be switched on.
3. Check fieldbus module signals:
 - The green bus LED indicates the operating status according to the corresponding description (☞ 7.4-1) Pos. **A**.
 - The yellow bus LED indicates the communication status according to the description (☞ 7.4-1) Pos. **B**.
 - Quick blinking (8 Hz) is the reaction of the yellow bus LED to impermissible settings. Please see chapter 7.7, "Troubleshooting and fault elimination".
4. You can now communicate with the drive.
 - With a PCP communication it is only possible to access the parameters of the controller after having executed the PCP service "Initiate" (☞ 7.6-50).
5. It is then possible to access the parameters via the PCP services "Read" and "Write" (☞ 7.6-50).

7.5.6 Prepare controller for INTERBUS operation

82XX / 8200 vector

Preparation	Notes
1. L-C0001 (operating mode): Change value from "0" to "3"	<p>For this use</p> <ul style="list-style-type: none"> the 8201BB for 82XX and the keypad for 8200 vector <p>Alternative: Direct access to the code via INTERBUS.</p> <p>Example Set code L-C0001 to "3" (PCP write):</p> <ul style="list-style-type: none"> Index: $5FFE_{\text{hex}} (= 5FFF_{\text{hex}} - (L-C0001)_{\text{hex}})$ Subindex: 0 Value: 30000_{dec} <p>→ For conversion formula and parameter value range see □ 7.6-47</p> <p>8200 vector (up to SW version 1.1) → C0410/y (y = 1...16) must be assigned to the AIF control word (AIF-CTRL) i.e. C0410/1 = 10, C0410/2 = 11 C0410/16 = 25 (see Operating Instructions for 8200 vector).</p>
2. Terminal 28 (controller enable) must be HIGH during INTERBUS operation. Terminal 28 is always active!	<p>Otherwise, the controller cannot be enabled by the INTERBUS (DRIVECOM controller status "OPERATION ENABLED", see Operating Instructions for the controller).</p> <p>821X, 8200vector und 822X With these controllers the QSP function is always active. If QSP is assigned to an input terminal (default setting: not assigned), this terminal must be at HIGH level during INTERBUS operation (see the corresponding Operating Instructions).</p>
The controller is now ready to accept process and parameter data from the INTERBUS.	

93XX controllers

Preparation	Notes
1. L-C0005: Set "xx3".	<p>Use the 9371BB keypad</p> <p>Alternative: Direct access to the code via INTERBUS. For the first commissioning you should select the signal configuration 1013 (speed control).</p> <p>Example Set code L-C0005 to "1013" (PCP write):</p> <ul style="list-style-type: none"> Index: $5FFA_{\text{hex}} (5FFF_{\text{hex}} - (L-C0005)_{\text{hex}})$ Subindex: 0 Value: 10130000_{dec} <p>→ For conversion formula and parameter value range see □ 7.6-47</p>
2. L-C0142 (autostart lock): Set "0".	Only necessary with DRIVECOM control
3. Terminal 28 (controller enable) must be HIGH during INTERBUS operation. Terminal 28 is always active!	<p>Otherwise, the controller cannot be enabled by the INTERBUS (DRIVECOM controller status "OPERATION ENABLED", see Operating Instructions for 93XX).</p> <p>→ With the signal configuration L-C0005=1013, the function QSP (quick stop) and the CW/CCW changeover are assigned to the digital input terminals E1 and E2 and thus they are always active. For INTERBUS operation E1 must be set to HIGH level (see Operating Instructions 93XX).</p> <p>→ With the signal configuration L-C0005=xx13, terminal A1 is switched as voltage output. Thus, only the following terminals can be connected via cables:</p> <ul style="list-style-type: none"> X5.A1 with X5.28 (ctrl. enable) X5.A1 with X5.E1 (CW/QSP)
The controller is now ready to accept process and parameter data from the INTERBUS.	

7.5.7 Controller enable via DRIVECOM

Controllers can be controlled with DRIVECOM process data. The INTERBUS master has direct access to the process data. In the INTERBUS master, data are stored in the I/O area.

- Controller enable: DRIVECOM process data word "Control word"
- Display of actual controller status: DRIVECOM process data word "Status word".

The controller can be enabled by changing to OPERATION ENABLED by means of the DRIVECOM control word.

Afterwards, the controller can be controlled as usual, e.g. via terminals.



Note!

If DRIVECOM control is active and the fieldbus module

- in the controller
 - 82XX / 8200 vector "controller inhibit" will be activated if L-C0001 = 3.
 - 93XX "Controller inhibit" will always be active.
- the fieldbus module sets SWITCH ON INHIBIT.

Enable the controller as follows:

1. Select speed setpoint (2nd process data word; PD2), value $\neq 0$.
2. Change to "READY FOR SWITCH ON"
PD output word1 = 0000 0000 0111 1110_{bin} (007E_{hex}).
3. Wait for the status "READY FOR SWITCH ON".
PD input word1 = xxxx xxxx x01x 0001_{bin}.
4. Change to "OPERATION ENABLED"
PD output word1 = 0000 0000 0111 1111_{bin} (007F_{hex}).
5. Wait for "OPERATION ENABLED".
PD input word1 = xxx xxx x01x 0111_{bin}.

7.5.8 DRIVECOM compatibility

The DRIVECOM profile 21 is a specification of important parameters and unit performance of several manufacturers. The DRIVECOM profile 21 mainly describes the unit control and a speed operating mode. In addition to the DRIVECOM specifications there are further Lenze-specific functions, e.g. digital-frequency connection or DC injection-brake. These manufacturer-specific specifications require minor changes in the settings to comply with the desired DRIVECOM compatibility. In the following, you will find the changes required for the Lenze controllers.

820X	With 820X controllers, parameters can only be set when the controller is inhibited. The controller is inhibited in DRIVECOM status. <ul style="list-style-type: none"> • "SWITCH-ON INHIBIT" • "READY FOR SWITCH ON" • "SWITCHED ON" • "TRIP"
821X, 8200 vector and 822X	The automatic DC-injection brake must be deactivated in all parameter sets, i. e. <ul style="list-style-type: none"> • L-C0106=0 • L-C2106=0 • L-C4106=0 (only 8200 vector) • L-C6106=0 (only 8200 vector) <p>If the automatic DC-injection brake is not deactivated (holding time of the DC-injection brake L-C0106 not 0), the controller automatically switches from the status "OPERATION ENABLED" to the status "SWITCHED ON" when the speed is 0 and the holding time of the DC-injection brake is elapsed. If the setpoint is higher than 0, the controller is automatically reset to the status "OPERATION ENABLED".</p>
93XX	Set the controller parameters for INTERBUS control, e.g. L-C0005=1013 This configuration corresponds to the signal configuration 1000 with the following changes: <ul style="list-style-type: none"> • Setpoint selection with INTERBUS • Unit control with INTERBUS • Output X5.A1 is selected as voltage output for the internal supply of the digital inputs. • Actual values and status signals for INTERBUS <p>For the detailed description of the signal configuration, see 93XX Manual.</p>
9300 Servo PLC	The following links must be made in the PLC program. <ul style="list-style-type: none"> • AIF1_wDctrlCtrl → DCTRL_wAIF1Ctrl • DCTRL_wStat → AIF1_wDctrlStat
Drive PLC	It is necessary to use the device control for the DRIVE PLC.

7.5.9 Special features when using 82XX, 8200 vector and 93XX



Danger!

Please note

- For safe operation it is absolutely necessary to observe the notes for the controllers given in this chapter.
- Please observe the corresponding Operating Instructions of the controllers.

820X	<ul style="list-style-type: none"> • Parameter setting (codes except process data) is only possible when the controller is inhibited (DRIVECOM controller status unequal "OPERATION ENABLED"). Parameters are accepted when the controller is enabled, but they are not saved. • A TRIP must only be reset through INTERBUS: If the controller is set to the status TRIP while being operated with INTERBUS control (L-C0001 = 3) and if the TRIP is reset through terminal 28, the drive can start for a short time. When resetting a fault via INTERBUS, this does not occur. • After the command "TRIP reset" the 820X controller is basically initialized. During this time the controller does not accept any services. • Always send the direction of rotation with a low setpoint before the new setpoint: If the setpoint and the direction of rotation are changed at the same time via the DRIVECOM speed setpoint, the speed can change to the wrong direction or rotation for a short time. This is because the setpoint is sent to the controller as unipolar value before and the information about the direction of rotation is sent.
8200 vector	<ul style="list-style-type: none"> • Digital and analog input and output signals can be freely configured (see Operating Instructions for 8200 vector; codes L-C0410, L-C0412, L-C0417 and L-C0421) • A change of code L-C0001 to "3" preconfigures the process data words in the controller.
93XX	<ul style="list-style-type: none"> • Set the signal configuration L-C0005 = xxx3 instead of the operating mode L-C0001. • The change of the code L-C0005 to xxx3 starts the preconfiguration of the process data words in the controller • Set the parameter L-C0142 = 0 (auto start lock), to avoid a short time start of the drive during the initialization phase.

7.6 Data transfer

INTERBUS master and slave communicate by sending data telegrams via the INTERBUS.

The user data of the data telegram contains parameter data or process data.

Different communication channels are assigned to parameter and process data:

Telegram type	Communication channel
Process data, <ul style="list-style-type: none"> • Setpoints • Actual values 	Process-data channel <ul style="list-style-type: none"> • Exchange between INTERBUS master and controller required as fast as possible. Small amounts of data for cyclic data transfer. • The INTERBUS master has direct access to the process data. • Process data can control the controller. • Process data are <ul style="list-style-type: none"> – not stored in the controller. – exchanged between INTERBUS master and controllers to ensure a constant update of input and output data.
Parameter data <ul style="list-style-type: none"> • Operating parameters • diagnostics information • motor data 	Parameter data channel or "PCP channel" (PCP = Peripherals Communication Protocol) <ul style="list-style-type: none"> • In general, the parameter transfer is not as time-critical as the transfer of process data. • Enables access to all Lenze codes and indexes.

Tab. 7.6-1 Division of parameter data and process data into different communication channels

The following describes the communication protocol only as much as needed for networking Lenze controllers.

7.6.1 Process data channel configuration

7.6.1.1 Process data transfer

Process data telegrams between INTERBUS master and the controllers connected to the INTERBUS are divided into:

- Process data telegrams **from** drive (PI)
- Process data telegrams **to** drive (PO)



Note!

As agreed, the data flow is described from the INTERBUS master's view:

- PI data of the INTERBUS master are output data for the controller.
- PO data of the INTERBUS master are input data for the controller.

Process data telegram from drive

For the cyclic process data telegram from the drive, the function block to be used is called AIF-OUT. The status word included in the process data telegram (byte 1 and byte 2) is sent to the INTERBUS master via this function block.

Process data telegram to drive

For the cyclic process data telegram to the drive, the function block to be used is called AIF-IN. The control word included in the process data telegram (byte 1 and byte 2) is sent to the INTERBUS master via this function block.

7.6.1.2 Setpoint source selection

82XX controllers

The setpoint source selection for these controllers is determined under code L-C0001 (5FFE_{hex}). An evaluation of process data is only possible if code L-C0001 is set to "3" when the controller is operated together with the fieldbus module. The process data channel which describes the frequency setpoint (L-C0046) and the control word (parameter channel, L-C0135) is the setpoint source.



Note!

Please ensure that the setpoint source (L-C0001) is the same for all parameter sets used.

Controller 8200 vector

The setpoint source selection for these controllers is determined under code L-C0001 (5FFE_{hex}). An evaluation of process data is only possible if code L-C0001 is set to "3" when the controller is operated together with the fieldbus module. The process data channel which describes the frequency setpoint (L-C0046) and the control word (parameter channel, L-C0135) is the setpoint source.

Check in L-C0412/x whether the assignment of setpoint source and analog signal is correct and change, if necessary.



Note!

Please ensure that the setpoint source selection (L-C0001) is the same for all parameter sets used.

93XX controllers

The value in code C0005 must be set to "xxx3" for bus operation (x = selected preconfiguration).

Servo PLC 9300 / Drive PLC

Communication requires that AIF-IN 1 ... 3 or AIF-OUT 1 ... 3 and if available the AIF management are part of the control configuration of the IEC61131 project.

7.6.1.3 Process data configuration

Some data important for the process must be transmitted as quickly as possible. These data are called process data and stored in the I/O area of the controller for access from the INTERBUS master.

The process data are cyclically exchanged between the controller and the INTERBUS master.

The process data of a **Process-data configuration** have a certain "Process data structure".

The process-data structure is subdivided into

- Process input data (PI data, index = 6000_{hex}, (□ 7.6-5))
- Process output data (PO data, index = 6001_{hex}, (□ 7.6-6))

The controller receives control information from the INTERBUS master and sends status information to the master.

The Lenze setting for the process-data length is 4 byte.

The PD length settings are made by means of

- DIP switch (□ 7.5-2) **or**
- Code L-C1910 (□ 7.5-4).

The contents of code L-C1910 is overwritten when the DIP switch is used because the DIP switch settings have higher priority.



Note!

The assignment of the AIF-CTRL control word to PO data is only useful, if the Drivecom status machine is switched off. This is achieved by entering 0 under L-C1911 or using the switch S7 at the front.

Different controller signals can be assigned to the PI and PO data words (see (□ 7.6-7)).

PI data description (6000_{hex})

The parameter describes the process data which are sent from the controller to the INTERBUS master (input data for the INTERBUS master). Parameters of the described process data assignment of Lenze controllers can be assigned to the sub-index values (see □ 7.6-7). Exception: The value for subindex 1 cannot be changed.

Ensure that the parameters of the process data channel are only used once, i.e. double assignment must be avoided (example: DC speed and speed setpoint are sent via AIF-W1).

Parameter name (Index)	Subindex	Data structure	Data type
PI data description (6000 _{hex})	1 ... 41	R	PBS(20 _{hex})



Note!

Only the valid subindex is displayed with the parameter 6000_{hex}. It is determined by PD!

Subindex	Meaning	Value	Lenze setting
1	Number of process data [byte]	PD • 2	
2	Index PI data word 1	6041 _{hex}	DRIVECOM status word
3	Subindex PI data word 1	00	
4/5	No entry	00	
6	Index PI data word 2	6044 _{hex}	DRIVECOM speed
7	Subindex PI data word 2	00	
8/9	No entry	00	
10	Index PI data word 3	5CA5 _{hex}	AIF-OUT.W2
11	Subindex PI data word 3	02 _{hex}	
12/13	No entry	00	
14	Index PI data word 4	5CA5 _{hex}	AIF-OUT.W3
15	Subindex PI data word 4	03 _{hex}	
16/17	No entry		
18	Index PI data word 5	5CA5 _{hex}	AIF-OUT.W4
19	Subindex PI data word 5	04 _{hex}	
20/21	No entry		
22	Index PI data word 6	5CA5 _{hex}	AIF-OUT.W5
23	Subindex PI data word 6	05 _{hex}	
24/25	No entry		
26	Index PI data word 7	5CA5 _{hex}	AIF-OUT.W6
27	Subindex PI data word 7	06 _{hex}	
28/29	No entry		
30	Index PI data word 8	5CA5 _{hex}	AIF-OUT.W7
31	Subindex PI data word 8	07 _{hex}	
32/33	No entry		
34	Index PI data word 9	5CA5 _{hex}	AIF-OUT.W8
35	Subindex PI data word 9	08 _{hex}	
36/37	No entry		
38	Index PI data word 10	5CA5 _{hex}	AIF-OUT.W9
39	Subindex PI data word 10	09 _{hex}	
40/41	No entry		

PO data description (6001_{hex})

The parameter describes the process data which are sent to the controller from the INTERBUS master (output data for the INTERBUS master). Parameters of the described process data of Lenze controllers can be assigned to subindex values (see (□ 7.6-7)). Exception: The value for subindex 1 cannot be changed.

Ensure that the parameters of the process data channel are only used once, i.e. double assignment must be avoided (example: DC speed and speed setpoint are sent via AIF-W1).

Parameter name (Index)	Subindex	Data structure	Data type
PO data description (6001 _{hex})	1 ... 41	R	PBS(20 _{hex})

Subindex	Meaning	Value	Lenze setting	Index 6002/ Bit
1	Number of process data [byte]	PD • 2		
2	Index PO data word 1	6040 _{hex}	DRIVECOM control word	0
3	Subindex PO data word 1	00		
4/5	No entry	00		1
6	Index PO data word 2	6042 _{hex}	DRIVECOM speed setpoint	2
7	Subindex PO data word 2	00		
8/9	No entry	00		3
10	Index PO data word 3	5CA7 _{hex}	AIF-IN.W2	4
11	Subindex PO data word 3	02 _{hex}		
12/13	No entry	00		5
14	Index PO data word 4	5CA7 _{hex}	AIF-IN.W3	6
15	Subindex PO data word 4	03 _{hex}		
16/17	No entry			7
18	Index PO data word 5	5CA7 _{hex}	AIF-IN.W4	8
19	Subindex PO data word 5	04 _{hex}		
20/21	No entry			9
22	Index PO data word 6	5CA7 _{hex}	AIF-IN.W5	10
23	Subindex PO data word 6	05 _{hex}		
24/25	No entry			11
26	Index PO data word 7	5CA7 _{hex}	AIF-IN.W6	12
27	Subindex PO data word 7	06 _{hex}		
28/29	No entry			13
30	Index PO data word 8	5CA7 _{hex}	AIF-IN.W7	14
31	Subindex PO data word 8	07 _{hex}		
32/33	No entry			15
34	Index PO data word 9	5CA7 _{hex}	AIF-IN.W8	16
35	Subindex PO data word 9	08 _{hex}		
36/37	No entry			17
38	Index PO data word 10	5CA7 _{hex}	AIF-IN.W9	18
39	Subindex PO data word 10	09 _{hex}		
40/41	No entry			19

7.6.2 Process data signals of Lenze controllers

7.6.2.1 Process data signals for frequency inverters 82XX

Process data telegram from
drive

The following parameters can be assigned to the **PI-data**:

Index	Subindex	Name	Explanation	Lenze setting: Index 6000 _{hex}	see
6041	0	DRIVECOM status word		PI data word 1	☞ 7.6-39
6044	0	DRIVECOM speed	Actual speed [rpm]	PI data word 2	☞ 7.6-42
6054	0	DRIVECOM actual percentage value	Actual speed [%] ± 100% = ± 16383		☞ 7.6-43
5F69	0	Device status word (L-C0150)			Table below
5CA5	1	AIF-OUT.W1	AIF word 1		

Device status word AIF-STAT for 82XX (Lenze code C0150, index 5F69_{hex})

Bit	820X	821x, 822x
0	Actual parameter set 0 = Parameter set 1 or 3 active 1 = Parameter set 2 or 4 active	Actual parameter set 0 = Parameter set 1 or 3 active 1 = Parameter set 2 or 4 active
1	IMP (pulse inhibit) 0 = Pulses for power stage enabled 1 = Pulses for power stage inhibited	IMP (pulse inhibit) 0 = Pulses for power stage enabled 1 = Pulses for power stage inhibited
2	I _{max} (current limit reached) 0 = Current limit not reached 1 = Current limit reached	I _{max} (current limit reached) 0 = Current limit not reached 1 = Current limit reached
3	not assigned	f _d = f _{dset} 0 = f _d ≠ f _{dset} 1 = f _d = f _{dset}
4	f _d = f _{dset} 0 = f _d ≠ f _{dset} 1 = f _d = f _{dset}	RFG on = RFG off 0 = RFG on ≠ RFG off 1 = RFG on = RFG out
5	Qmin (f _d ≤ f _{dQmin}) 0 = Qmin not active 1 = Qmin active	Qmin (f _d ≤ f _{dQmin}) 0 = Qmin not active 1 = Qmin active
6	f _d + 0 (act. frequency = 0) 0 = f _d ≠ 0 1 = f _d + 0	f _d + 0 (act. frequency = 0) 0 = f _d ≠ 0 1 = f _d + 0
7	Ctrl. inhibit (controller inhibit) 0 = Controller not inhibited 1 = Controller inhibited	Ctrl. inhibit (controller inhibit) 0 = Controller not inhibited 1 = Controller inhibited
8...11	Controller status 0 = Unit initialisation 8 = Error active	Controller status 0 = Controller initialization 2 = Switch on inhibit 3 = Operation inhibited 4 = Flying-restart circuit active 5 = DC brake active 6 = Operation enabled 7 = Message active 8 = Error active
12	Overtemperature warning 0 = No warning 1 = Warning	Overtemperature warning 0 = No warning 1 = Warning
13	V _{Gmax} (DC-bus overvoltage) 0 = No overvoltage 1 = Overvoltage	V _{Gmax} (DC-bus overvoltage) 0 = No overvoltage 1 = Overvoltage
14	Direction of rotation 0 = CW rotation 1 = CCW rotation	Direction of rotation 0 = CW rotation 1 = CCW rotation
15	Ready for operation 0 = Not ready for operation 1 = Ready for operation	Ready for operation 0 = Not ready for operation 1 = Ready for operation

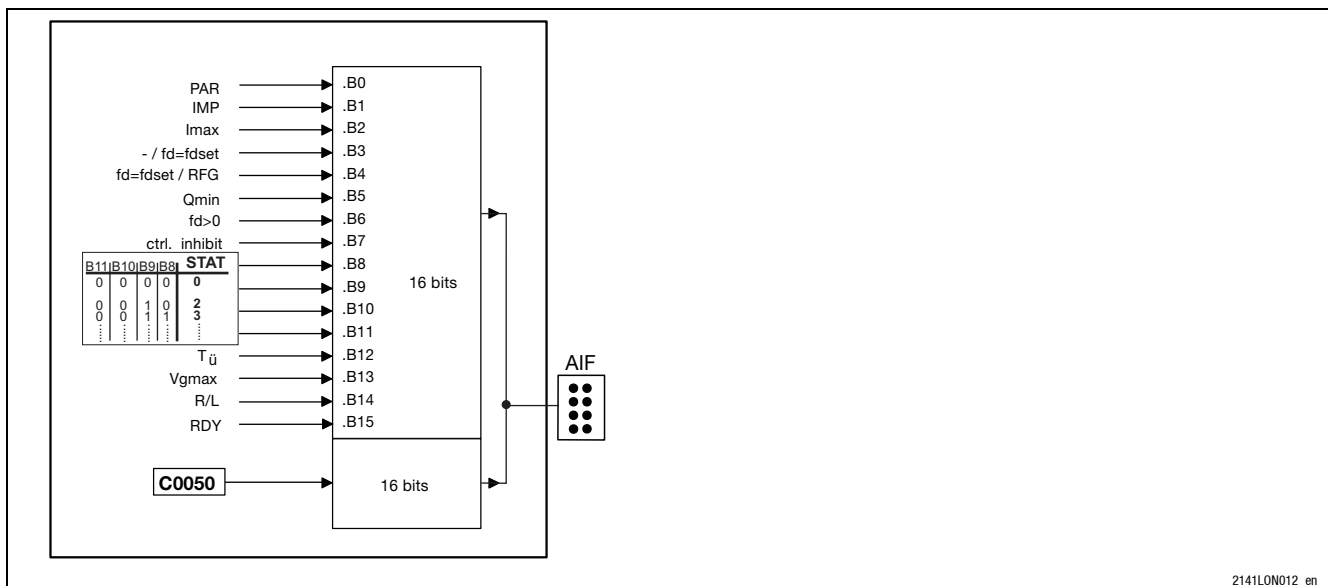

Fig. 7.6-1 Read access to status word and actual frequency in 82XX (fixed assignment)

2141LON012_en

Process data telegram to drive

The following parameters can be assigned to the **PO-data**:

Index	Subindex	Name	Explanation	Lenze setting: Index 6001 _{hex}	see
6040	0	DRIVECOM control word		PO data word 1	7.6-36
6042	0	DRIVECOM speed setpoint	Speed setpoint [rpm]	PO data word 2	7.6-42
6052	0	DRIVECOM percentage setpoint	Speed setpoint [%] ± 100% = ± 16383		7.6-43
5F78	0	Device control word (L-C0135)			Table below
5CA7	1	AIF-IN.W1	AIF word 1. See the following description.		



Note!

The assignment of the AIF-CTRL control word to PO data is only useful, if the Drivecom status machine is switched off. This is achieved by entering 0 under L-C1911 or using the switch S7 at the front.

Control word AIF-CTRL for 82XX (Lenze code C0135, index 5F78_{hex})

Bit	820X		821x, 822x	
00, 01	00 = C0046 active 01 = JOG1 active in C0037 10 = JOG2 active in C0038 11 = JOG3 active in C0039		00 = C0046 active 01 = JOG1 active in C0037 10 = JOG2 active in C0038 11 = JOG3 active in C0039	
02	CW/CCW (CW rotation/ CCW rotation)	0 = CW rotation 1 = CCW rotation	CW/CCW (CW rotation/CCW rotation)	0 = CW rotation 1 = CCW rotation
03	QSP (quick stop)	0 = QSP not active 1 = QSP active	QSP (quick stop)	0 = QSP not active 1 = QSP active
04	Reserved		RFG stop (stop of the ramp function generator)	0 = RFG stop not active 1 = RFG stop active
05			RFG zero (deceleration along the T _{if} ramp C0013)	0 = RFG zero not active 1 = RFG zero active
06			UP function for motor potentiometer	0 = UP not active 1 = UP active
07			DOWN function for motor potentiometer	0 = DOWN not active 1 = DOWN active
08			Reserved	
09	Ctrl. inhibit (controller inhibit)	0 = Controller not inhibited 1 = Controller inhibited	Ctrl. inhibit (controller inhibit)	0 = Controller not inhibited 1 = Controller inhibited
10	Reserved		Reserved	
11	Reserved		TRIP reset	0 -> 1 = Edge from 0 to 1
12	PAR1 (Parameter set changeover)	0 -> 1 = Parameter set 1 -> 0 = Parameter set	PAR1 (Parameter set changeover)	0 -> 1 = Parameter set 1 -> 0 = Parameter set
13	Reserved		Reserved	
14	DC brake (DC injection brake)	0 = DC brake not active 1 = DC brake active	DC brake (DC injection brake)	0 = DC brake not active 1 = DC brake active
15	Reserved		Reserved	

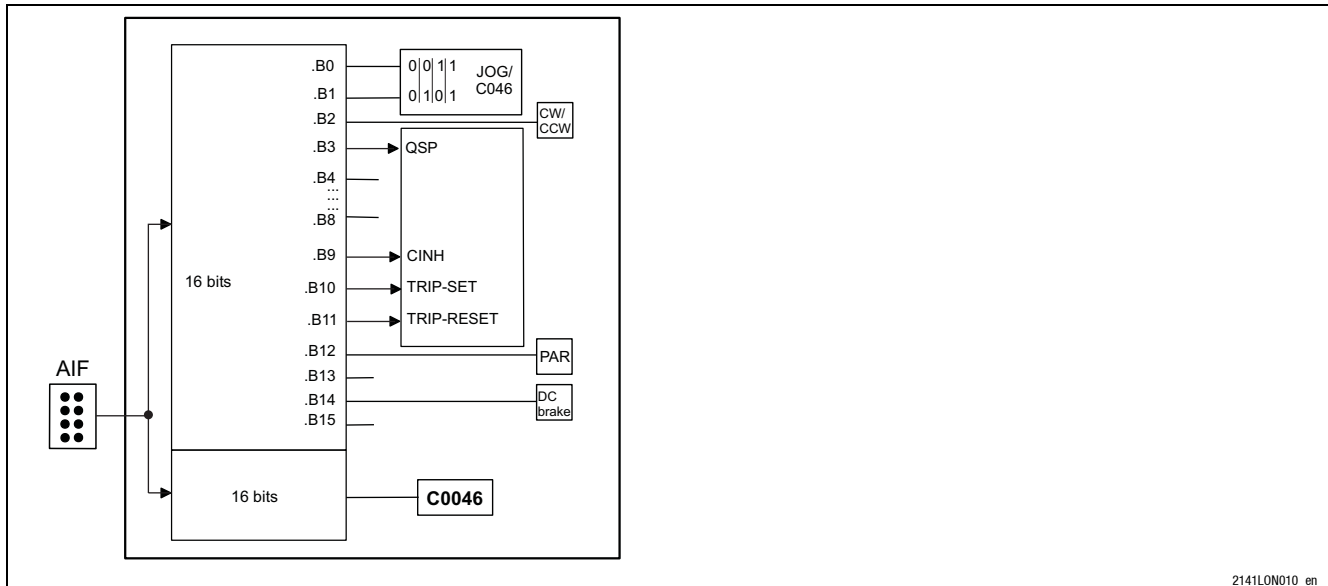

Fig. 7.6-2 Access to control word and actual frequency in 82XX (fixed assignment)

7.6.2.2 Process data signals for 8200 vector frequency inverters

The function block AIF (AIF=automation interface) is the data interface between the 8200 vector and the fieldbus module. The function block consists of AIF-OUT and AIF-IN.

Process data telegram from
drive

The following parameters can be assigned to the **PI-data**:

Index	Subindex	Name	Explanation	Lenze setting: Index 6000 _{hex}	see
6041	0	DRIVECOM status word		PI data word 1	☞ 7.6-39
6044	0	DRIVECOM speed	Actual speed [rpm]	PI data word 2	☞ 7.6-42
6054	0	DRIVECOM actual percentage value	Actual speed [%] ± 100% = ± 16383		☞ 7.6-43
5F69	0	Device status word (L-C0150)			Table below
5CA5	1	AIF-OUT.W1	AIF word 1		
	2	AIF-OUT.W2	AIF word 2	PI data word 3	

AIF-OUT.Wx is parameterised under code L-C0421.

Controller status word AIF-STAT for 8200 vector (Lenze code C0150, index 5F69_{hex})

AIF-STAT.Bxx	Lenze setting	Adjustable in code L-0417/..
0	DCTRL1-PAR-B0	1
1	DCTRL1-IMP	2
2	MCTRL1-IMAX	3
3	MCTRL1-RFG1=NOUT	4
4	NSET1-RFG1-I=0	5
5	PCTRL1-QMIN	6
6	DCTRL1-NOUT=0	7
7	DCTRL1-CINH	8
8...11	Controller status 0 = Controller initialization 2 = Switch on inhibit 3 = Operation inhibited 4 = Flying-restart circuit active 5 = DC brake active 6 = Operation enabled 7 = Message active 8 = Error active	Reserved
12	DCTRL1-OH-WARN	13
13	DCTRL1-OV	14
14	DCTRL1-CCW	15
15	DCTRL1-RDY	16

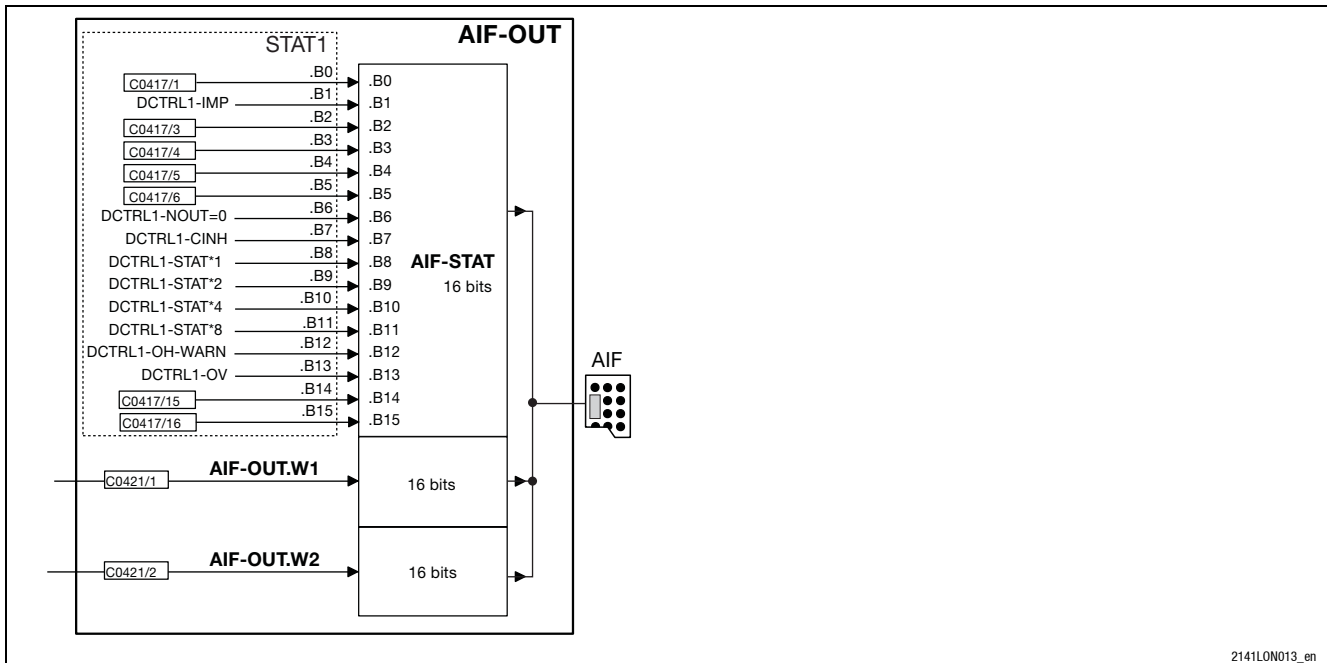

Fig. 7.6-3 Function block AIF-OUT in 8200 vector (freely programmable assignment)

2141LON013_en

Process data telegram to drive

The following parameters can be assigned to the **PO-data**:

Index	Subindex	Name	Explanation	Lenze setting: Index 60001 _{hex}	see
6040	0	DRIVECOM control word		PO data word 1	7.6-36
6042	0	DRIVECOM speed setpoint	Speed setpoint [rpm]	PO data word 2	7.6-42
6052	0	DRIVECOM percentage setpoint	Speed setpoint [%] ± 100% = ± 16383		7.6-43
5F78	0	Device control word (L-C0135)			Table below
5CA7	1	AIF-IN.W1	AIF word 1 Frequency and speed are normalised with ± 24000 ≙ ± 480 Hz.		
	2	AIF-IN.W2	AIF word 2 Frequency and speed are normalised with ± 24000 ≙ ± 480 Hz.	PO data word 3	

AIF-IN.Wx is parameterised under code L-C0412.



Note!

The assignment of the AIF-CTRL control word to PO data is only useful, if the Drivecom status machine is switched off. This is achieved by entering 0 under L-C1911 or using the switch S7 at the front.

Control word AIF-CTRL for 8200 vector (Lenze code C0135, index 5F78_{hex})

AIF-CTRL.Bxx	Default setting: C0001=3 if C0007 ≤ 51		Default setting: C0001=3 if C0007 > 51		Adjustable in L-C0410/..
00, 01	00 = C0046 active 01 = NSET1-JOG1 (C0037) active 10 = NSET1-JOG2 (C0038) active 11 = NSET1-JOG3 (C0039) active		Freely configurable by user		1 2
02	DCTRL1-CW/CCW	0 = not active 1 = active			3
03	AIF-CTRL-QSP	0 = not active 1 = active	AIF-CTRL-QSP	0 = not active 1 = active	4
04	NSET1-RFG1-STOP	0 = not active 1 = active			5
05	NSET1-RFG1-0	0 = not active 1 = active			6
06	MPOT1-UP	0 = not active 1 = active	Freely configurable by user		7
07	MPOT1-DOWN	0 = not active 1 = active			8
08	Freely configurable by user				9
09	AIF-CTRL-CINH	0 = not active 1 = active	AIF-CTRL-CINH	0 = not active 1 = active	10
10	AIF-CTRL-TRIP-SET	0 = not active 1 = active	AIF-CTRL-TRIP-SET	0 = not active 1 = active	11
11	AIF-CTRL-TRIP-RESET	0 -> 1 = Edge from 0 to 1	AIF-CTRL-TRIP-RESET	0 -> 1 = Edge from 0 to 1	12
12	DCTRL1-PAR2/4	0 = not active 1 = active			13
13	DCTRL1-PAR3/4	0 = not active 1 = active	Freely configurable by user		14
14	MCTRL1-DCB	0 = not active 1 = active			15
15	Freely configurable by user		Freely configurable by user		16

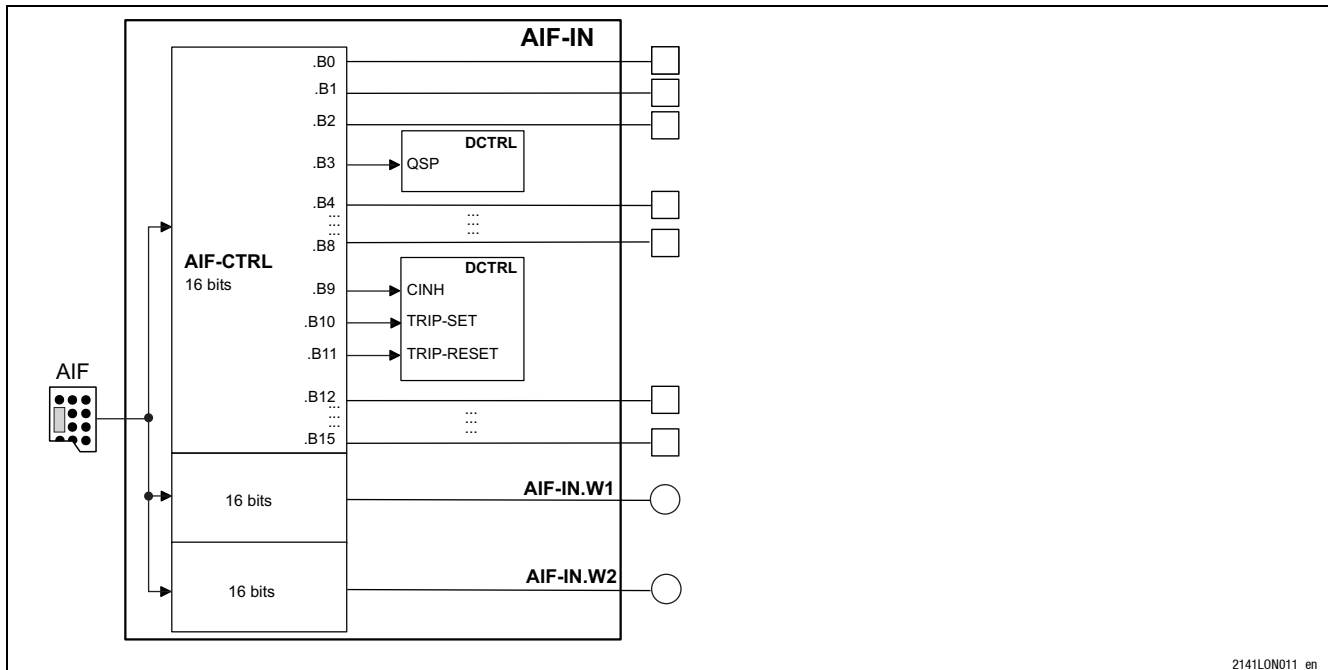

Fig. 7.6-4 Function block AIF-IN in 8200 vector (freely programmable assignment)

2141LON011_en

7.6.2.3 Process data signals for servo inverters 9300

The function block AIF (AIF=automation interface) is the data interface between the 93XX controller and the fieldbus module. The function block consists of AIF-OUT and AIF-IN.

With the 93XX controller the process data assignment can be changed by reconfiguring the function blocks AIF-IN and AIF-OUT.

Process data telegram from
drive

The following parameters can be assigned to the **PI-data**:

Index	Subindex	Name (same in IEC1131)	Explanation	Lenze setting: Index 6000 _{hex}	see
6041	0	DRIVECOM status word		PI data word 1	☐ 7.6-39
6044	0	DRIVECOM speed	Actual speed [rpm]	PI data word 2	☐ 7.6-42
6054	0	DRIVECOM actual percentage value	Actual speed [%]		☐ 7.6-43
5F69	0	Device status word (AIF1_Stat)			Table below
5CA5	1	AIF1-OUT.W1	AIF word 1		
5CA5	2	AIF1-OUT.W2	AIF word 2	PI data word 3	
5CA5	3	AIF1-OUT.W3	AIF word 3	PI data word 4	
5CA4	0	AIF1-OUT.D1	AIF double word		

The assignment of AIF-OUT depends on the signal configuration selected under L-C0005:

Signal configuration (L-C0005)	AIF-OUT.W1	AIF-OUT.W2	AIF-OUT.W3	AIF-OUT.D1
Speed control				
1003	MCTRL-NACT	MCTRL-MSET2	MCTRL-NSET2	not assigned
1013	Actual speed	Torque display	Speed controller input	
1113	± 100% = ± 16383	± 100% = ± 16383	± 100% = ± 16383	
Torque control				
4003	MCTRL-MSET2	MCTRL-NACT	MCTRL-NSET2	not assigned
4013	Torque display	Act. speed in %	Speed controller input	
4113	± 100% = ± 16383	± 100% = ± 16383	± 100% = ± 16383	
DF master				
5003	MCTRL-NACT	MCTRL-MSET2	MCTRL-NSET2	not assigned
5013	Actual speed	Torque display	Speed controller input	
5113	± 100% = ± 16383	± 100% = ± 16383	± 100% = ± 16383	
DF-slave bus				
6003	MCTRL-NACT	MCTRL-PHI-ACT	MCTRL-MSET2	not assigned
6013	Actual speed	Actual phase	Torque setpoint in %	
6113	± 100% = ± 16383		± 100% = ± 16383	
DF-slave cascade				
7003	MCTRL-NACT	MCTRL-PHI-ACT	MCTRL-MSET2	not assigned
7013	Actual speed	Actual phase	Torque setpoint in %	
7113	± 100% = ± 16383		± 100% = ± 16383	
Not equal to xxx3 (except self configurations)	MCTRL-NACT	MCTRL-MSET2	MCTRL-PHI-ACT	not assigned
	Actual speed	Torque display	Actual phase	
	± 100% = ± 16383	± 100% = ± 16383		

For detailed description of the 93XX signal configuration see the Operating Instructions for 93XX (only the main configurations: 1000, 4000, 5000, etc.) or the Manual 93XX.

In the controller, other signals can be assigned to AIF-OUT.W1 to AIF-OUT.W3. For this, the function-block configuration - described in the Manual 93XX - is used. The function block AIF-OUT determines the output data of the controller as data interface for the 2133 fieldbus module.

For more detailed information about the function block AIF-OUT, see the Manual 93XX.

Controller status word AIF-STAT for 93XX

Bit..	9300 Servo				9300 POS L-C0005:	9300 CRV	9300 Vector		
	1xx3	4xx3	5xx3	6xx3,7xx3	2xxx3	xxx3	1xxx, 2xxx, 3xxx, 5xxx, 10xxx, 11xxx	4xx3	6xx3,7xx3
0	DCTRL-PAR1-0	DCTRL-PAR1-0	DCTRL-PAR1-0	DCTRL-PAR1-0	not assigned	CERR1-ERR	DCTRL-PAR1-0	DCTRL-PAR1-0	DCTRL-PAR1-0
1	DCTRL-IMP	DCTRL-IMP	DCTRL-IMP	DCTRL-IMP	DCTRL-IMP	DCTRL-IMP	DCTRL-IMP	DCTRL-IMP	DCTRL-IMP
2	MCTRL-IMAX	MCTRL-IMAX	REF-OK	REF-OK	POS-REF-OK	MCTRL-IMAX	MCTRL-IMAX	MCTRL-IMAX	MCTRL-IMAX
3	MCTRL-MMAX	not assigned	MCTRL-MMAX	not assigned	not assigned	MCTRL-MMAX	MCTRL-MMAX	MCTRL-IMAX negated	MCTRL-MMAX
4	NSET-RFG-I=0	MCTRL-IMAX negated	NSET-RFG-I=0	MCTRL-IMAX negated	MCTRL-MMAX negated	DCTRL-TRIP	NSET-RFG-I=0	NSET-RFG-I=0	NSET-QSP-OUT
5	QMIN	QMIN	REF-BUSY	REF-BUSY	POS-IN-TARGET	CDATA-X0	QMIN	QMIN	QMIN
6	DCTRL- NACT=0	DCTRL- NACT=0	DCTRL- NACT=0	DCTRL- NACT=0	DCTRL- NACT=0	DCTRL- NACT=0	DCTRL- NACT=0	DCTRL- NACT=0	DCTRL- NACT=0
7	DCTRL-CINH	DCTRL-CINH	DCTRL-CINH	DCTRL-CINH	DCTRL-CINH	DCTRL-CINH	DCTRL-CINH	DCTRL-CINH	DCTRL-CINH
8 ... 11	Controller status: 0 = Unit initialisation 2 = Switch-on inhibit 3 = Operation inhibited 4 = Flying-restart circuit active 5 = DC-injection brake active 6 = Operation enabled 7 = Message active 8 = Fault active 10 = Fail-QSP (only 9300 servo positioning controller)								
12	DCTRL-WARN	DCTRL-WARN	DCTRL-WARN	DCTRL-WARN	DCTRL-WARN	DCTRL-WARN	DCTRL-WARN	DCTRL-WARN	DCTRL-WARN
13	DCTRL-MESS	DCTRL-MESS	DCTRL-MESS	DCTRL-MESS	DCTRL-MESS	DCTRL-MESS	DCTRL-MESS	DCTRL-MESS	DCTRL-MESS
14	DCTRL-CW/ CCW	DCTRL-CW/ CCW	DCTRL-CW/ CCW	not assigned	DCTRL-AIFL- QSP	DCTRL-CW/ CCW	DCTRL-CW/ CCW	DCTRL-CW/ CCW	DCTRL-CW/ CCW
15	DCTRL-RDY	DCTRL-RDY	DCTRL-RDY	DCTRL-RDY	DCTRL-RDY	DCTRL-RDY	DCTRL-RDY	DCTRL-RDY	DCTRL-RDY

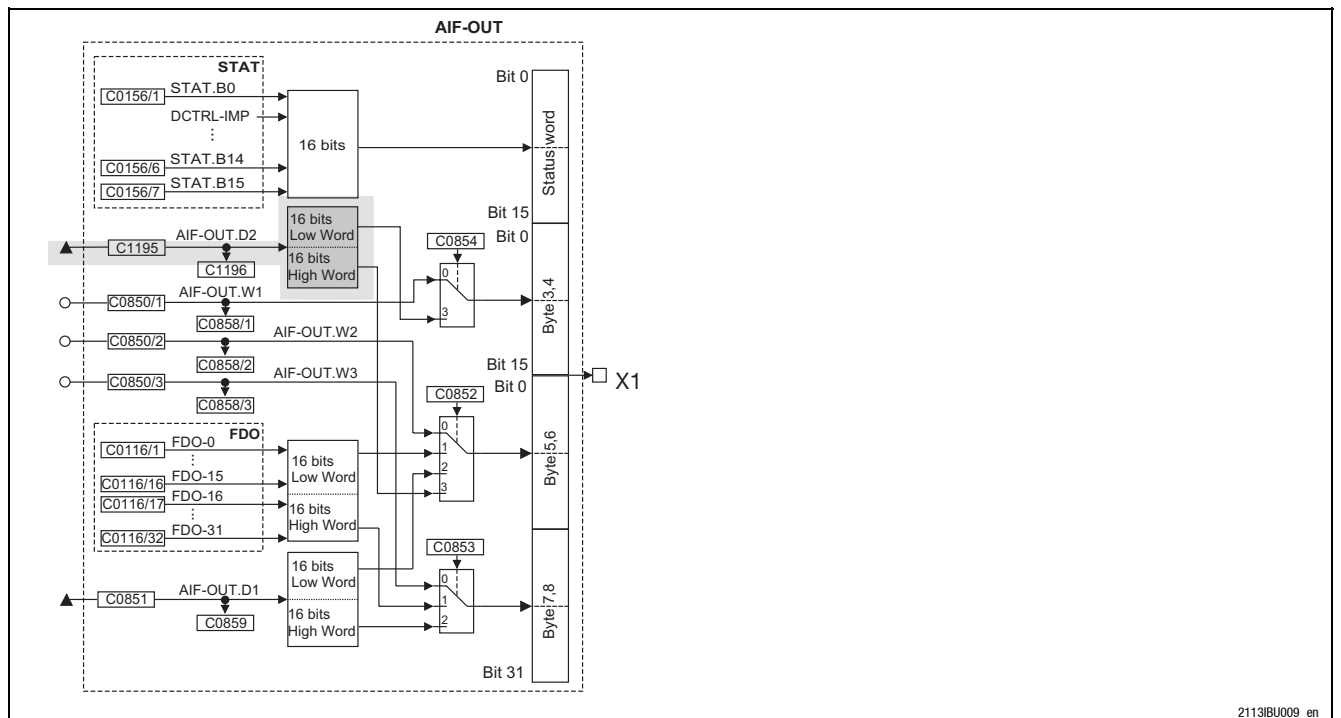

Fig. 7.6-5 Function block AIF-OUT (function block extension on grey background: available as of software version 2.0 on)

Process data telegram to drive

The following parameters can be assigned to the **PO-data**:

Index	Subindex	Name	Explanation	Lenze setting: Index 6001 _{hex}	see
6040	0	DRIVECOM control word		PO data word 1	☐ 7.6-36
6042	0	DRIVECOM speed setpoint	Speed setpoint [rpm]	PO data word 2	☐ 7.6-42
6052	0	DRIVECOM percentage setpoint	Speed setpoint [%] ± 100% = ± 16383		☐ 7.6-43
5F78	0	Device control word (AIF1_CTRL)			Table below
5CA7	1	AIF-IN.W1	AIF word 1		
5CA7	2	AIF-IN.W2	AIF word 2	PO data word 3	
5CA7	3	AIF-IN.W3	AIF word 3	PO data word 4	
5CA6	0	AIF-IN.D1	AIF double word		

**Note!**

The assignment of the AIF-CTRL control word to PO data is only useful, if the Drivecom status machine is switched off. This is achieved by entering 0 under L-C1911 or using the switch S7 at the front.

The assignment of AIF-IN.W1 to AIF-IN.W3 depends on the signal configuration selected under L-C0005:

Signal configuration (L-C0005)	AIF-IN.W1	AIF-IN.W2	AIF-IN.W3	AIF-IN.D1
Speed control 1003 / 1013 / 1113	NSET-N Speed setpoint	not assigned	not assigned	not assigned
Torque control 4003 / 4013 / 4113	MCTRL-MADD Torque setpoint	not assigned		
DF master 5003 / 5013 / 5113	NSET-N Speed setpoint	not assigned		
DF-slave bus 6003 / 6013 / 6113	DFSET-A-TRIM Phase trimming	DFSET-N-TRIM Speed trimming		
DF-slave cascade 7003 / 7013 / 7113	DFSET-VP-DIV DF factor	DFSET-A-TRIM Phase trimming		
not equal to xxx3	not assigned	not assigned		

For detailed description of the 93XX signal configuration see the Operating Instructions for 93XX (only the main configurations: 1000, 4000, 5000, etc.) or the Manual 93XX.

In the controller, other signals can be assigned to AIF-IN.W1 to AIF-IN.W3. For this, the function-block configuration - described in the Manual 93XX - is used. The function block AIF-IN determines the input data of the controller as data interface for the 2133 fieldbus module.

For more detailed information about the function block AIF-IN, see the Manual 93XX.

Control word AIF-CTRL for 93XX

Bit	9300 Servo				9300 POS	9300 CRV	9300 Vector		
	1xx3	4xx3	5xx3	6xx3,7xx3	L-C0005: 2xxx3	xxx3	1xxx, 2xxx, 3xxx, 5xxx, 10xxx, 11xxx	4xx3	6xx3,7xx3
0	NSET-JOG*1	not assigned	NSET-JOG*1	not assigned	not assigned	CSEL1-CAM*1	NSET-JOG*1	not assigned	not assigned
1	NSET-JOG*2	not assigned	NSET-JOG*2	not assigned	not assigned	CSEL1-CAM*2	NSET-JOG*2	not assigned	not assigned
2	NSET-N-INV	NSET-N-INV	NSET-N-INV	NSET-N-INV	not assigned	CSEL1-CAM*4	NSET-N-INV	not assigned	not assigned
3	AIF-CTRL.QSP	AIF-CTRL.QSP	AIF-CTRL.QSP	AIF-CTRL.QSP	AIF-CTRL.QSP	AIF-CTRL.QSP	AIF-CTRL.QSP	AIF-CTRL.QSP	AIF-CTRL.QSP
4	NSET-RFG-STOP	NSET-RFG-STOP	NSET-RFG-STOP	NSET-RFG-STOP	POS-PRG-START	CSEL1-EVENT	NSET-RFG-STOP	NSET-RFG-STOP	not assigned
5	NSET-RFG-0	NSET-RFG-0	NSET-RFG-0	NSET-RFG-0	POS-PRG-STOP	CDATA-CYCLE	NSET-RFG-0	NSET-RFG-0	not assigned
6	not assigned	not assigned	not assigned	not assigned	not assigned	CSEL1-LOAD	not assigned	not assigned	not assigned
7	not assigned	not assigned	not assigned	not assigned	POS-PRG-RESET	CSEL1-LOAD	not assigned	not assigned	not assigned
8	not assigned	not assigned	not assigned	not assigned	not assigned	not assigned	not assigned	not assigned	not assigned
9	AIF-CTRL.CINH	AIF-CTRL.CINH	AIF-CTRL.CINH	AIF-CTRL.CINH	AIF-CTRL.CINH	AIF-CTRL.CINH	AIF-CTRL.CINH	AIF-CTRL.CINH	AIF-CTRL.CINH
10	AIF-CTRL.TRIP-SET	AIF-CTRL.TRIP-SET	AIF-CTRL.TRIP-SET	AIF-CTRL.TRIP-SET	AIF-CTRL.TRIP-SET	AIF-CTRL.TRIP-SET	AIF-CTRL.TRIP-SET	AIF-CTRL.TRIP-SET	AIF-CTRL.TRIP-SET
11	AIF-CTRL.TRIP-RESET	AIF-CTRL.TRIP-RESET	AIF-CTRL.TRIP-RESET	AIF-CTRL.TRIP-RESET	AIF-CTRL.TRIP-RESET	AIF-CTRL.TRIP-RESET	AIF-CTRL.TRIP-RESET	AIF-CTRL.TRIP-RESET	AIF-CTRL.TRIP-RESET
12	DCTRL-PAR*1	DCTRL-PAR*1	DCTRL-PAR*1	DCTRL-PAR*1	POS-PS-CANCEL	not assigned	DCTRL-PAR*1	DCTRL-PAR*1	DCTRL-PAR*1
13	DCTRL-PAR-LOAD	DCTRL-PAR-LOAD	DCTRL-PAR-LOAD	DCTRL-PAR-LOAD	POS-PARAM-RD	not assigned	DCTRL-PAR-LOAD	DCTRL-PAR-LOAD	DCTRL-PAR-LOAD
14	NSET-Ti*1	NSET-JOG*1	REF-ON	REF-ON	POS-LOOP-ONH	not assigned	NSET-Ti*1	NSET-JOG*1	not assigned
15	NSET-Ti*2	NSET-JOG*2	NSET-Ti*1	not assigned	POS-STBY-STP	not assigned	NSET-Ti*2	NSET-JOG*2	not assigned

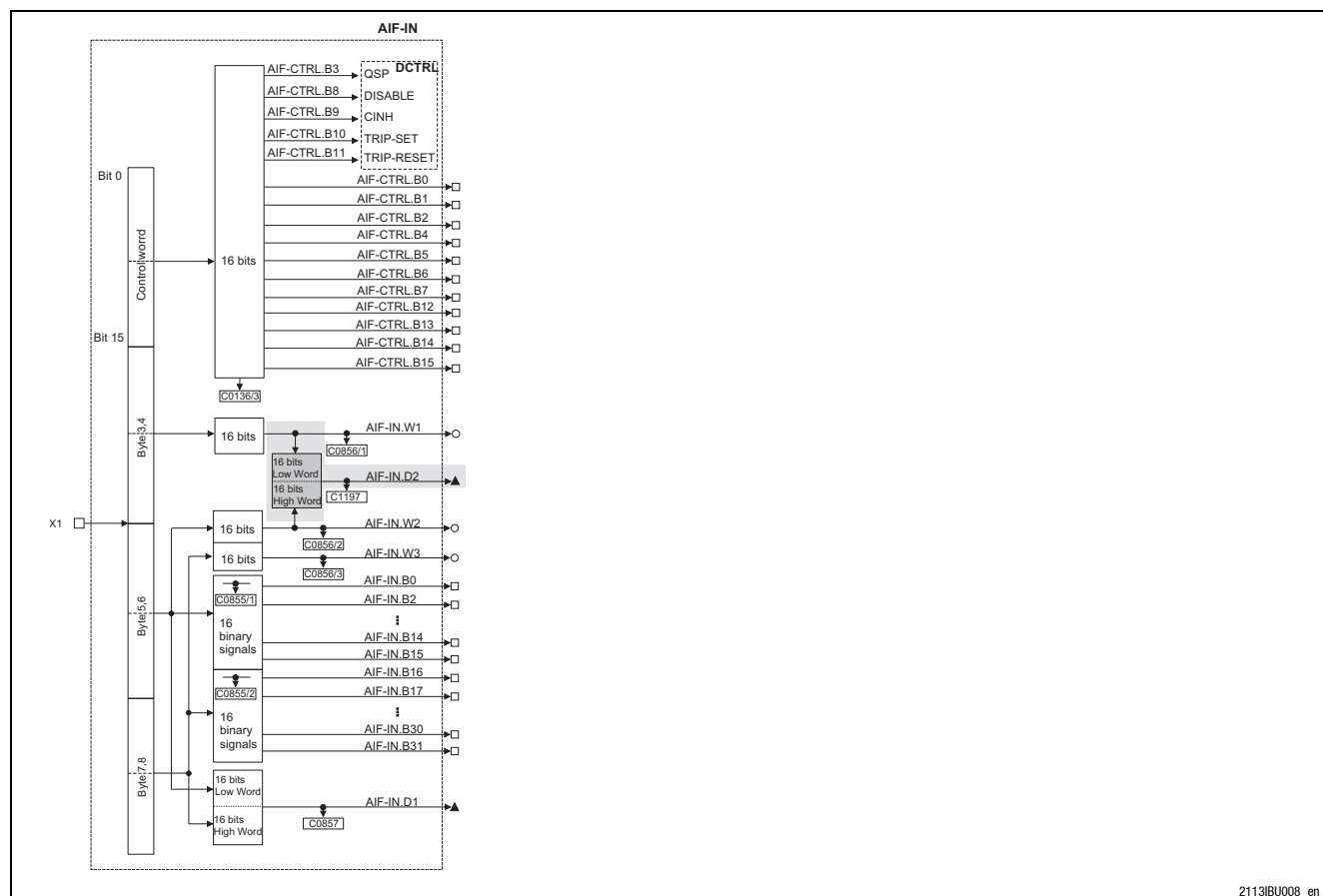

Fig. 7.6-6 Function block AIF-IN (grey: Extension available as of software version 2.0)

7.6.2.4 Process data signals for 9300 servo PLC and Drive PLC

Process data telegram from drive

The following data can be assigned to the PE data:

Index	Subindex	Name/variable name	Explanation	Lenze setting: Index 6000 _{hex}
6041	0	DRIVECOM status word		PI data word 1
6044	0	DRIVECOM speed	Actual speed [rpm]	PI data word 2
6054	0	DRIVECOM actual percentage value	Actual speed [%]	
5F69	0	Device status word (AIF1_DctrlStat)		
5CA5	1	AIF_nOutW1_a	AIF word 1	
5CA5	2	AIF_nOutW2_a	AIF word 2	PI data word 3
5CA5	3	AIF_nOutW3_a	AIF word 3	PI data word 4
5CA5	4	AIF2_nOutW1_a	AIF word 4	PO data word 5
5CA5	5	AIF2_nOutW2_a	AIF word 5	PO data word 6
5CA5	6	AIF2_nOutW3_a	AIF word 6	PO data word 7
5CA5	7	AIF2_nOutW4_a	AIF word 7	PO data word 8
5CA5	8	AIF3_nOutW1_a	AIF word 8	PO data word 9
5CA5	9	AIF3_nOutW2_a	AIF word 9	PO data word 10
5CA5	10	AIF3_nOutW3_a	AIF word 10	
5CA5	11	AIF3_nOutW4_a	AIF word 11	
5CA4	0	AIF1_dnOutD1_p	AIF double word 1	



Note!

9300 Servo PLC

Please execute the following logic operations in the PLC program of the controller:

AIF1_wDctrlCtrl → DCTRL_wAIF1Ctrl

DCTRL_wStat → AIF1_wDctrlStat

Drive PLC

It is necessary to use the device control for the Drive PLC.

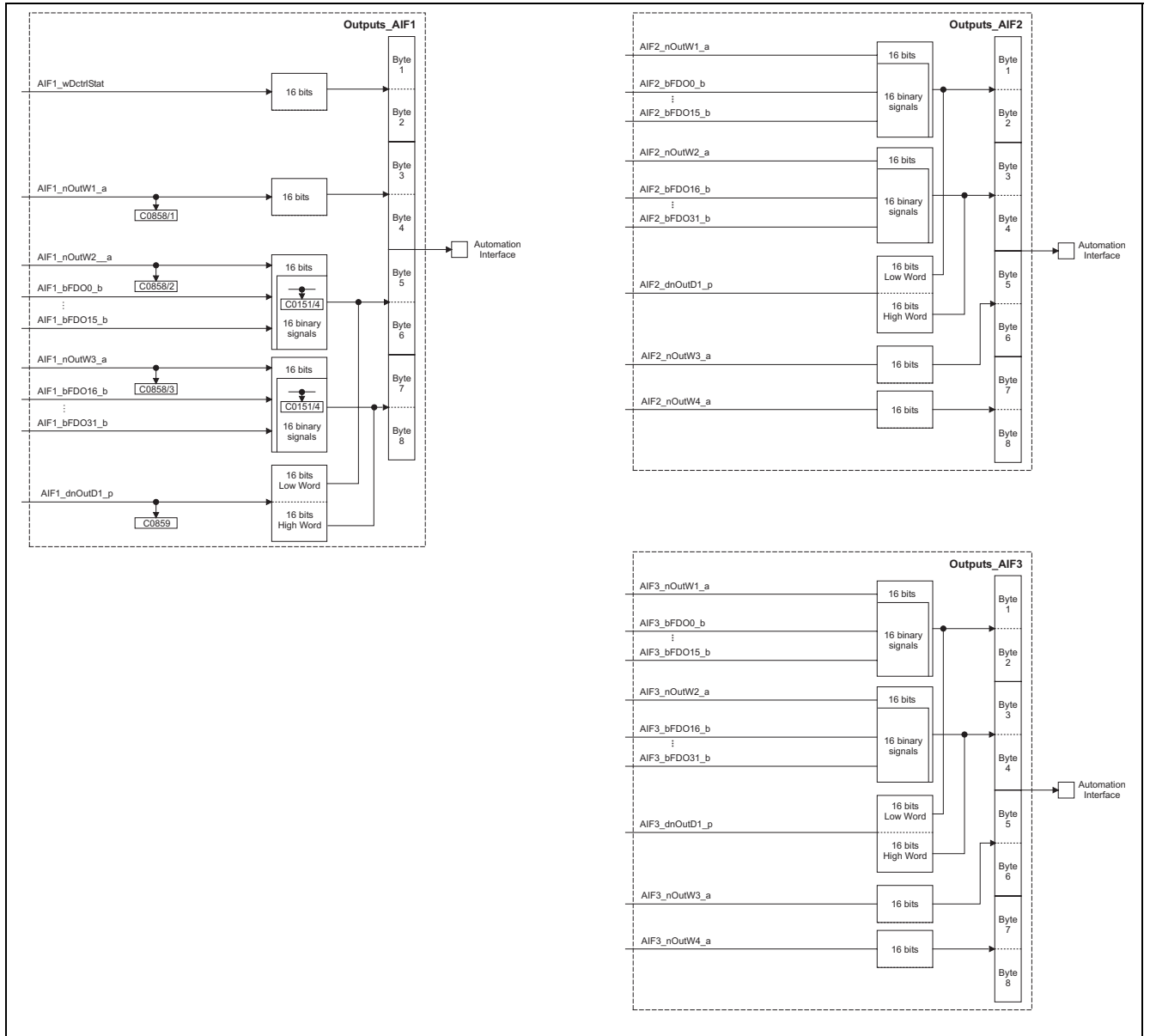

Fig. 7.6-7 Function blocks AIF-OUT1, AIF-OUT2 and AIF-OUT3

Process data telegram to drive

The following data can be assigned to the PA data:

Index	Subindex	Name/variable name	Explanation	Lenze setting: Index 6001 _{hex}
6040	0	DRIVECOM control word		PO data word 1
6042	0	DRIVECOM speed setpoint	Speed setpoint [rpm]	PO data word 2
6052	0	DRIVECOM percentage setpoint	Speed setpoint [%]	
5F78	0	Device control word (AIF1_wDctrlCtrl)		
5CA7	1	AIF1_nlnW1_a	AIF word 1	
5CA7	2	AIF1_nlnW2_a	AIF word 2	PO data word 3
5CA7	3	AIF1_nlnW3_a	AIF word 3	PO data word 4
5CA7	4	AIF2_nlnW1_a	AIF word 4	PO data word 5
5CA7	5	AIF2_nlnW2_a	AIF word 5	PO data word 6
5CA7	6	AIF2_nlnW3_a	AIF word 6	PO data word 7
5CA7	7	AIF2_nlnW4_a	AIF word 7	PO data word 8
5CA7	8	AIF3_nlnW1_a	AIF word 8	PO data word 9
5CA7	9	AIF3_nlnW2_a	AIF word 9	PO data word 10
5CA7	10	AIF3_nlnW3_a	AIF word 10	
5CA7	11	AIF3_nlnW4_a	AIF word 11	
5CA6	0	AIF1_dlnD1_p	AIF double word 1	

**Note!****9300 Servo PLC**

Please execute the following logic operations in the PLC program of the controller:

AIF1_wDctrlCtrl → DCTRL_wAIF1Ctrl

DCTRL_wStat → AIF1_wDctrlStat

Drive PLC

It is necessary to use the device control for the Drive PLC.

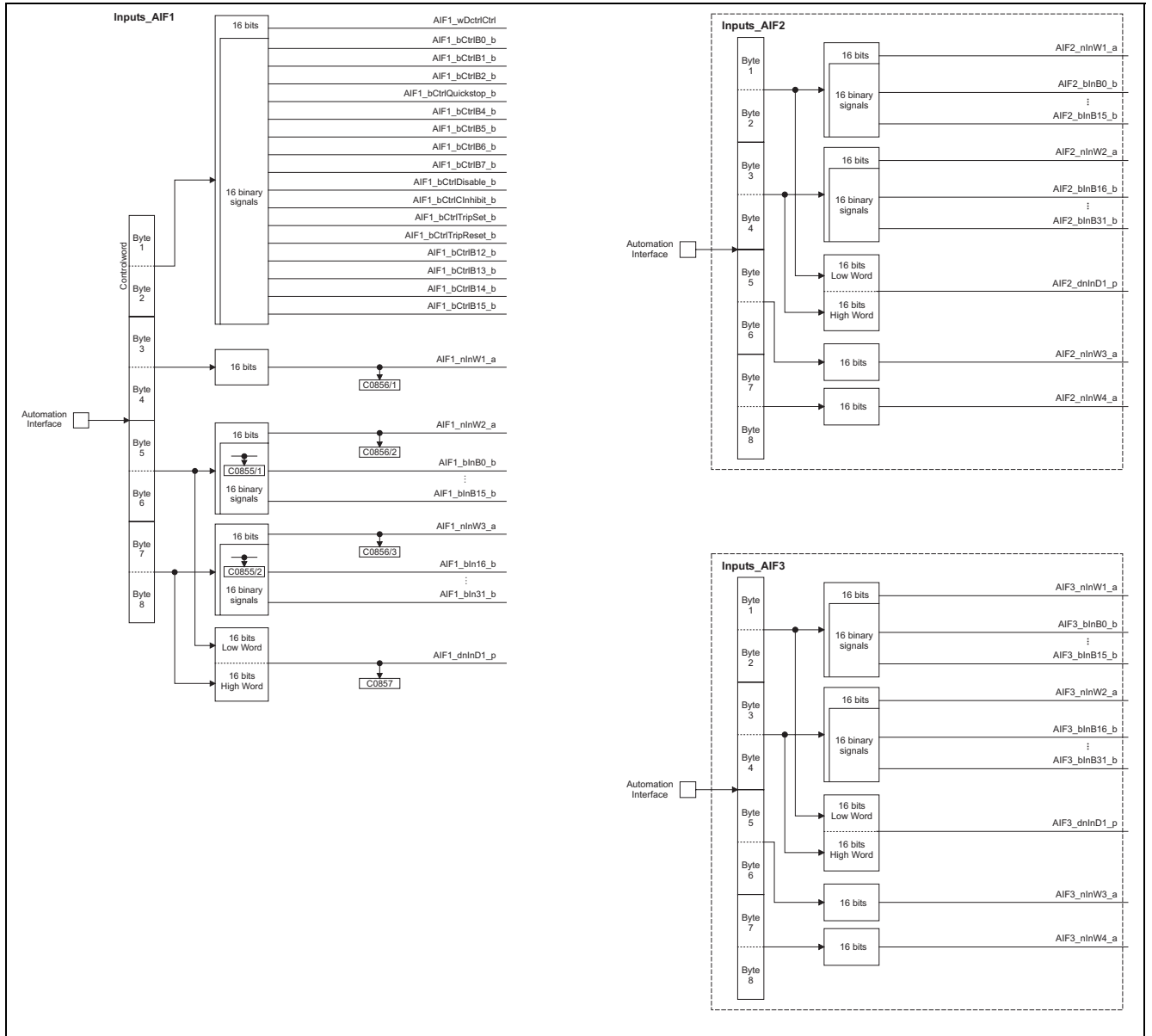

Fig. 7.6-8 Function blocks AIF-IN1, AIF-IN2 and AIF-IN3

7.6.3 Process data preconfiguration depending on L-C0009

Use L-C0009 to assign predefined values to the process data words (see table below).

This preconfiguration is meant to help you with applications which do not require a PCP.

Presettings for the process data configuration can be made under code L-C0009 using the Drive PLC or any controller (82XX, 8200 vector, 93XX) even if the INTERBUS is not connected.

It is also possible to configure the fieldbus module through the parameter channel via index 6000_{hex} and 6001_{hex}.

The process data configuration resulting from L-C0009 is automatically

- stored in the process data description structure when the device is switched on.
→ Index 6000_{hex} (☐ 7.6-5) / Index 6001_{hex} (☐ 7.6-6).
- immediately active.
- automatically writes the process data length (PD) in L-C1910 and DRIVECOM in L-C1911 from the table. A change of the PD length will only become active if the mains is switched on again and all DIP switches S1 - S7 are OFF.

The default setting of L-C0009 is "1" and influences the process data configuration.

L-C0009	2111 compatibility (S1-S7 OFF)		PD word 1	PD word 2	PD word 3	PD word 4	PD word 5	PD word 6	PD word 7	PD word 8	PD word 9	PD word 10
	PD	DRIVECOM										
11	2	0	GSTW	AIF-W1	-	-	-	-	-	-	-	-
12	2	0	AIF-W1	AIF-W2	-	-	-	-	-	-	-	-
13	2	0	AIF-W2	AIF-W3	-	-	-	-	-	-	-	-
14	2	1	DCSTW*	DCG	-	-	-	-	-	-	-	-
15	2	1	DCSTW*	DCG %	-	-	-	-	-	-	-	-
16	2	1	DCSTW*	AIF-W1	-	-	-	-	-	-	-	-
17	2	0	GSTW	DCG	-	-	-	-	-	-	-	-
18	2	0	GSTW	DCG %	-	-	-	-	-	-	-	-
21	3	1	DCSTW*	DCG	AIF-W2	AIF-W3	AIF-W4	AIF-W5	AIF-W6	AIF-W7	AIF-W8	AIF-W9
22	3	1	DCSTW*	DCG %	AIF-W2	AIF-W3	AIF-W4	AIF-W5	AIF-W6	AIF-W7	AIF-W8	AIF-W9
23	3	1	DCSTW*	AIF-W1	AIF-W2	AIF-W3	AIF-W4	AIF-W5	AIF-W6	AIF-W7	AIF-W8	AIF-W9
24	3	1	DCSTW*	AIF-W2	AIF-W3	AIF-W4	AIF-W5	AIF-W6	AIF-W7	AIF-W8	AIF-W9	AIF-W10
25	3	0	GSTW	AIF-W1	AIF-W2	AIF-W3	AIF-W4	AIF-W5	AIF-W6	AIF-W7	AIF-W8	AIF-W9
26	3	0	GSTW	AIF-W2	AIF-W3	AIF-W4	AIF-W5	AIF-W6	AIF-W7	AIF-W8	AIF-W9	AIF-W10
27	3	0	AIF-W1	AIF-W2	AIF-W3	AIF-W4	AIF-W5	AIF-W6	AIF-W7	AIF-W8	AIF-W9	AIF-W10

* ☐ 7.6-30

GSTW: Device control word/device status word
AIF-Wx: AIF-IN/OUT.Wx
DCSTW: DRIVECOM control word/DRIVECOM status word
DCG: DRIVECOM speed [rpm]
DCG %: DRIVECOM speed [%]

Parameter values from preconfiguration: ☐ 7.8-4

Examples for process data preconfiguration

Example 1: DRIVECOM control with 2 process data words (e.g. configuration L-C0009 = 14)	
Settings/measures	<ol style="list-style-type: none"> 1. Remove the fieldbus module and disconnect it from the voltage supply 2. Set L-C0009 = 14 (e.g. via keypad) 3. DIP switches S1 - S7 = OFF. 4. Attach the fieldbus module again and connect it to the voltage supply
Result	<ul style="list-style-type: none"> • The indexes 6000_{hex} and 6001_{hex} accept the configurations DCSTW and DCG. • The process data length (PD) is set to 2 words by L-C1910 = 4. • DRIVECOM is activated with L-C1911 = 1.
Acceptance of settings	The fieldbus module must be switched on again to activate the process data word length.

Example 2: Device control with 2 process data words (e.g. configuration L-C0009 = 25)	
Settings/measures	<ol style="list-style-type: none"> 1. Remove the fieldbus module and disconnect it from the voltage supply 2. Set L-C0009 = 25 (e.g. via keypad) 3. DIP switches S1 - S7 = OFF. 4. Attach the fieldbus module again and connect it to the voltage supply
Result	<ul style="list-style-type: none"> • The indexes 6000_{hex} and 6001_{hex} accept the configurations GSTW, AIF-W1, AIF-W2. • The process data length (PD) is set to 3 words by L-C1910 = 6. • DRIVECOM is activated by L-C1911 = 0.
Acceptance of settings	The fieldbus module must be switched on again to activate the process data word length.

Example 3: DRIVECOM control with 5 process data words (e.g. configuration L-C0009 = 21)	
Settings/measures	<ol style="list-style-type: none"> 1. Remove the fieldbus module and disconnect it from the voltage supply 2. Set L-C0009 = 21 (e.g. via keypad) 3. DIP switch <ul style="list-style-type: none"> – S1 = OFF, S2 = ON, S3 = OFF, S4 = ON (PD = 5 words) – S5/S6: Set required PCP data word length – S7 = ON (DRIVECOM activated) 4. Attach the fieldbus module again and connect it to the voltage supply
Result	<ul style="list-style-type: none"> • The indexes 6000_{hex} and 6001_{hex} accept the configurations DCSTW, DCG, AIF-W2, AIF-W3, AIF-W4. • Codes L-C1910 = 6 and L-C1911 = 1 are written, but are not active (DIP switch in position "ON").
Acceptance of settings	A process data word length of 5 words and DRIVECOM are <u>immediately</u> active through switches.



Example 4: Configuration of 10 PD words to AIF interface (configuration L-C0009 = 27).	
Settings/measures	<ol style="list-style-type: none"> 1. Remove the fieldbus module and disconnect it from the voltage supply 2. Set L-C0009 = 27 (e.g. via keypad) 3. DIP switch <ul style="list-style-type: none"> – S1 = ON, S2 = OFF, S3 = ON, S4 = OFF (PD = 10 words) – S5 = OFF, S6 = OFF: no PCP – S7 = OFF (DRIVECOM deactivated) 4. Attach the fieldbus module again and connect it to the voltage supply
Result	<ul style="list-style-type: none"> • The indexes 6000_{hex} and 6001_{hex} accept the configurations AIF-W1 AIF-W10. • Codes L-C1910 = 6 and L-C1911 = 1 are written, but are not active (DIP switch in position "ON").
Acceptance of settings	All switch settings become active <u>immediately</u> .

7.6.4 Examples for the configuration of PI/PO data

PI data configuration

The PI data word 2 is to be assigned to the actual percentage (index = 6054_{hex}).

Procedure:

- | |
|--|
| <p>1. Data type derived from the code table  7.6-43.</p> <ul style="list-style-type: none"> – The data type of the parameter actual percentage value is I16, i.e. it is a word parameter (16 bit). The code table for the parameter "Process input data description structure" (index = 6000_{hex}) shows that the PI data word 2 is to be entered under subindex 6 and 7 (word parameters). – The subindex of the parameter "PI data description" (index = 6000_{hex}) can be written with the PCP service "Write" (see  7.6-50). |
| <p>2. Enter the index of the parameter "Actual percentage": Write (index = 6000_{hex}, subindex = 6_{hex}, value = 6054_{hex})</p> |
| <p>3. Enter the subindex of the parameter "Actual percentage": Write (index = 6000_{hex}, subindex = 7_{hex}, value = 0_{hex})</p> |



Note!

The index must be changed to zero to change a subindex.
You can then change the subindex before the index.

PO data configuration

The PO data word 2 is to be assigned to the percentage setpoint (index = 6052_{hex}).

Procedure:

1. Data type derived from the code table  7.6-43.
 → The data type of the parameter "Percentage setpoint" is I16, i.e. it is a word parameter (16 bit). The code table for the parameter "Process output data description structure" (index = 6001_{hex}) shows that the PO data word 2 is to be entered under subindex 6 and 7 (word parameters).
 The subindex of the parameter "PO data description" (index = 6001_{hex}) can be described with the PCP service "Write".



Note!

The description of PO data results in inconsistent data, as the data are exchanged between controller and INTERBUS master in very short cycle times.

Therefore, the PO data are automatically inhibited when changing the PO data configuration. After the adaptation of the PO data to the new configuration, the data can be enabled via the parameter "PO data enable" (index 6002_{hex}).

2. Enter the index of the parameter "Percentage setpoint": Write (index = 6001_{hex}, subindex = 6_{hex}, value = 6054_{hex})
3. Enter the subindex of the parameter "Percentage setpoint": Write (index = 6001_{hex}, subindex = 7_{hex}, value = 0_{hex})



Note!

The index must be changed to zero to change a subindex.
 You can then change the subindex before the index.

4. Enter the index of the parameter "PO data enable" (6002_{hex}) to enable process data : Write (index = 6002_{hex}, subindex = 0_{hex}, value = FFFFFFFF_{hex})
- Now the PO data can be read again from the controller.



Note!

If a parameter is configured for PO data (e.g. the parameter "Control word" (6040_{hex}) in Lenze setting), it is not possible to write this parameter directly via its index (example: index = 6040_{hex})

7.6.5 Device control

**Note!**

Deactivate the DRIVECOM control if you want to use the device control (AIF-CTRL). For this use either code L-C1911 or the DIP switch S7 (▣ 7.5-1)

If you use the device control AIF-CTRL, the control information is determined by the control inputs (terminal) (▣ 7.6-3).

Explanation: Fig. 7.6-9

- **Status word:**
The controller status word AIF-STAT contains information about the current controller status.
- **Commands**
 - in the DRIVECOM parameter "Control word" are switched off and cannot change the controller status.
 - for changing the controller status are to be entered through the corresponding control input.

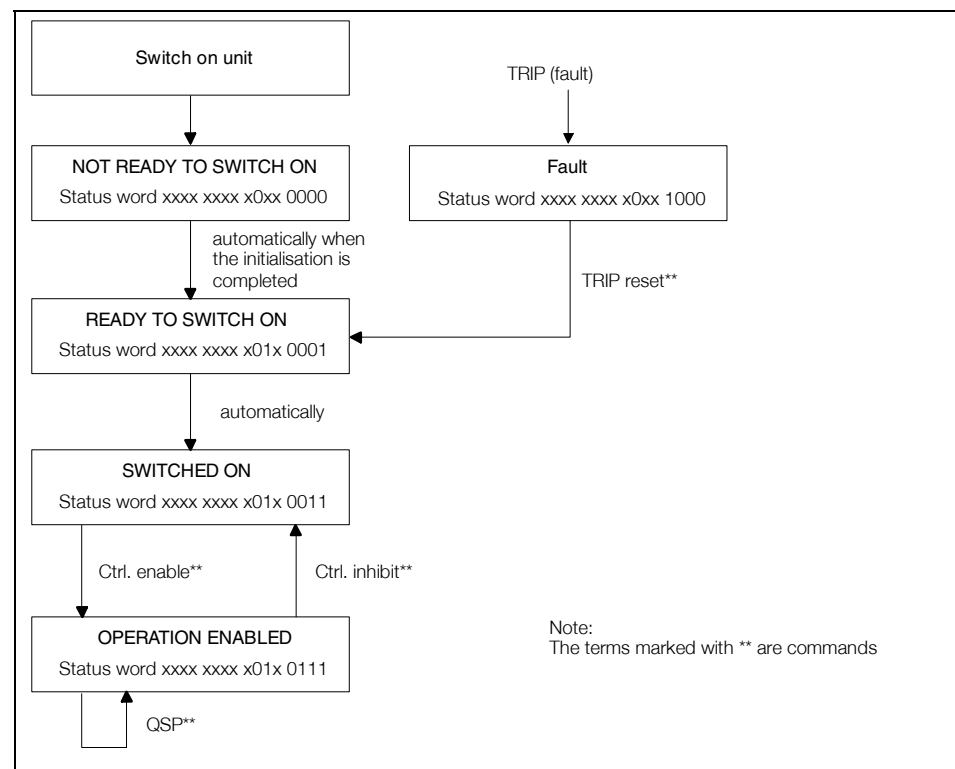

Fig. 7.6-9 Status diagram for device control AIF-CTRL

Data transfer

7.6

Device control

7.6.5

Status	Meaning
NOT READY TO SWITCH ON	The controller is still in the initialisation phase and not ready for operation. It then automatically switches to the status READY TO SWITCH ON.
READY TO SWITCH ON	The controller is inhibited and waits for the power stage to be charged. It then automatically switches to the status "SWITCHED ON".
SWITCHED ON	The controller is inhibited and waits for controller enable.
OPERATION ENABLED	The controller is enabled. In this status, a pulse inhibit can be set automatically.
FAULT	The controller is in the status "FAULT" (TRIP).

7.6.6 DRIVECOM control

With INTERBUS control (for 82XX/8200vector: Lenze parameter L-C0001 = 3; for 93XX: always) and when using the fieldbus module, Lenze controllers have a controller status according to the DRIVECOM profile 21.

Explanation: Fig. 7.6-10

- The DRIVECOM parameter "Status word" contains information about the current controller status. Marked by rectangles.
- Commands in the DRIVECOM parameter "Control word" can change the controller status. Marked by arrows.

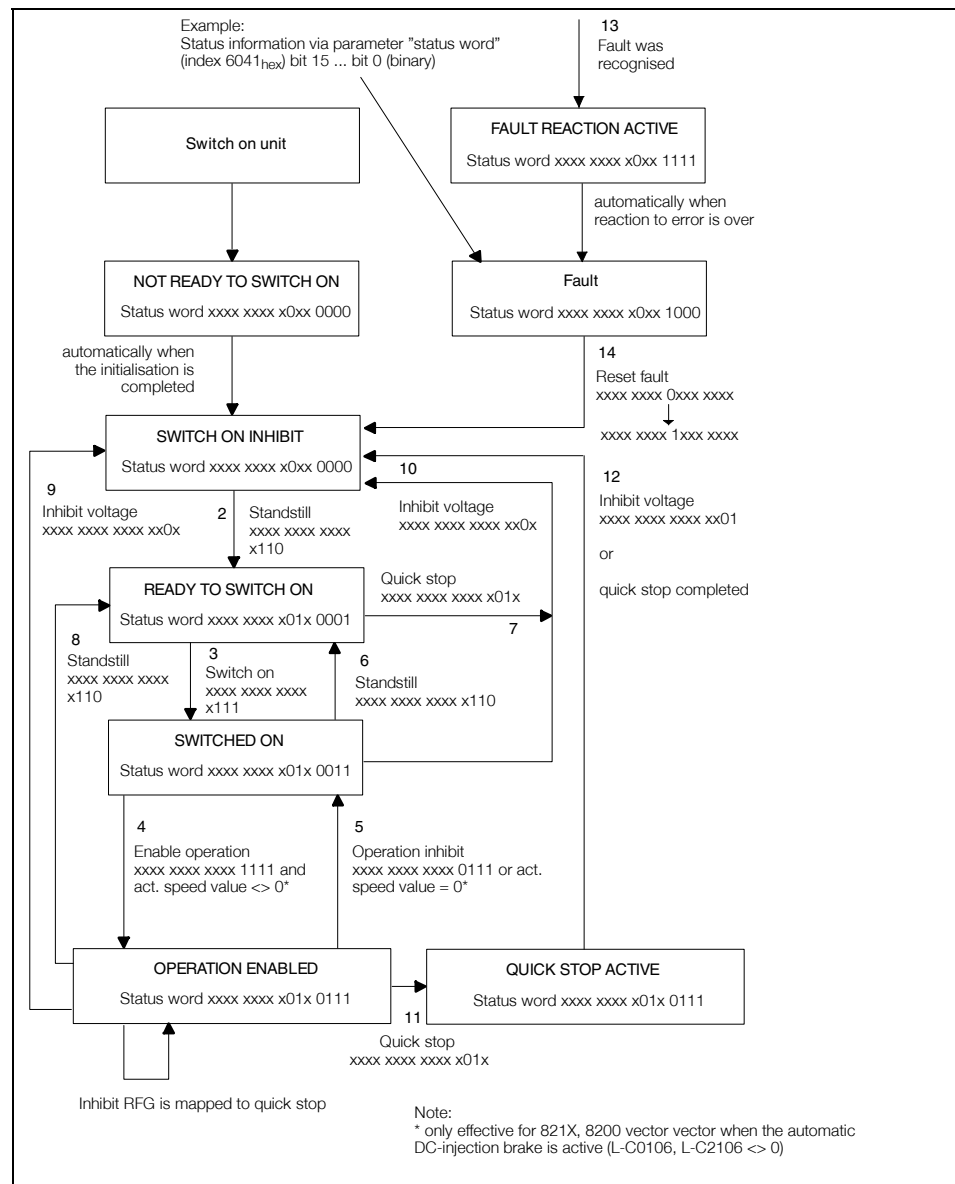

Fig. 7.6-10 Status diagram: DRIVECOM control

Explanation of the status diagram for DRIVECOM control

Status	Meaning
NOT READY TO SWITCH ON	The controller is being initialised and is not yet ready to operate. It then automatically switches to the status READY TO SWITCH ON.
SWITCH ON INHIBIT	The controller is inhibited and waits for command 2 (shut down).
READY TO SWITCH ON	The controller is inhibited and waits for command 3 (switch on).
SWITCHED ON	The controller is inhibited and waits for command 4 (enable operation).
OPERATION ENABLED	The controller is enabled. In this status, a pulse inhibit can be set automatically.
FAULT REACTION ACTIVE	A fault (TRIP) was recognised and a fault response initiated.
FAULT	The controller is in the status "FAULT" (TRIP).
QUICK STOP ACTIVE	While being in the status "OPERATION ENABLED" the command "quick stop" was set. The controller is decelerated in a controlled way (quick-stop ramp). After deceleration, the controller automatically changes to the controller status "SWITCH ON INHIBIT".



Note!

The actual unit status can only be clarified by combining the unit-status information bits (bit 0 to 6). This is shown in the following:

Controller status	Bits of the status word						
	6	5	4	3	2	1	0
NOT READY TO SWITCH ON	0			0	0	0	0
SWITCH ON INHIBIT	1			0	0	0	0
READY TO SWITCH ON	0	1		0	0	0	1
SWITCHED ON	0	1		0	0	1	1
OPERATION ENABLED	0	1		0	1	1	1
FAULT	0			1	0	0	0
FAULT REACTION ACTIVE	0			1	1	1	1
QUICK STOP ACTIVE	0	0		0	1	1	1

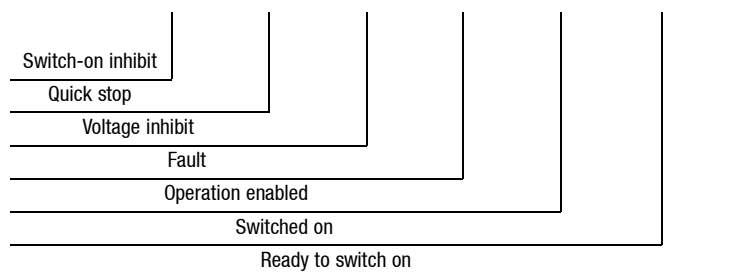

- 0 = Bit status is 0
- 1 = Bit status is 1
- no entry = Any bit status, no influence

Explanation of the commands in the status diagram for DRIVECOM control

Command	Meaning
COMMAND 2, 6, 8 (standstill) Control word: bit 0 = 0	Command to change from different states to the status "READY TO SWITCH ON".
COMMAND 3 (switch on)	Command to change to the controller status "SWITCHED ON".
COMMAND 4 (enable operation)	Command to change to the controller status "OPERATION ENABLED". The controller inhibit is deactivated.
COMMAND 5 (inhibit operation)	Command to change to the controller status "SWITCHED ON". The controller inhibit is activated.
COMMAND 7, 9, 10, 12 (voltage inhibit) Control word: bit 1 = 0	Command to change to the controller status "SWITCH ON INHIBIT". The controller inhibit is activated.
COMMAND 7, 10, 11 (quick stop) Control word: bit 2 = 0	Command to change to the controller status "SWITCH ON INHIBIT". If the controller was enabled, it is decelerated in a controlled way along the Lenze quick-stop ramp.
COMMAND 13 (malfunction/TRIP)	The controller has recognised a malfunction. For some malfunction a controlled deceleration may be necessary (depending on the controller). Once completed, the controller changes to the status FAULT.
COMMAND 14 (reset fault/TRIP) Control word: bit 7 = 0 ⇒ 1	With the series 821X, 8200 vector this command acknowledges an error. The controller changes to the status "SWITCH ON INHIBIT" when a fault is no longer recognised.



Note!

The single bit-control commands depend on other bit positions. In the following you will find a description of the bits required to effect the command.

Controller status commands	Bits of the control word							
	7	6	5	4	3	2	1	0
1 Standstill						1	1	0
2 Switch on						1	1	1
3 Operation enable					1	1	1	1
4 Operation inhibit					0	1	1	1
5 Voltage inhibit							0	
6 Quick stop						0	1	
8 Error reset	0→1							

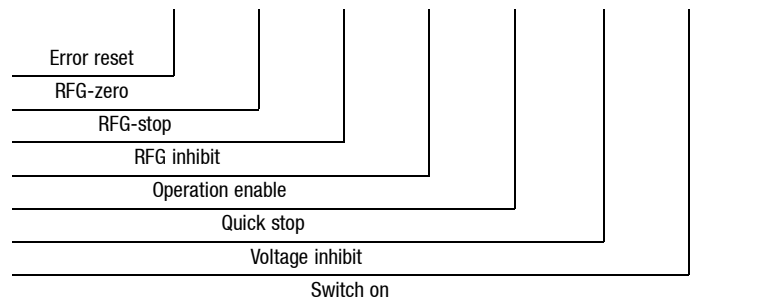

- 0 = Bit status is 0
- 1 = Bit status is 1
- no entry = Any bit status, no influence

7.6.7 DRIVECOM profile parameters

7.6.7.1 Process data description

PI data description (6000_{hex}) The description is on page (□ 7.6-5).

PO data description (6001_{hex}) The description is on page (□ 7.6-6).

PO data enable (6002_{hex}) The parameter enables or inhibits the PO data (output data for INTERBUS master). By this, the consistency of the PO data is guaranteed.

Output data inhibit: 00000000_{hex}

Output data enable: FFFFF_{hex}

Every bit enables a process data byte!

If you change 6001_{hex}, the changed process data bytes will be inhibited automatically. That means, that the controller does not receive new control data until index 6002_{hex} enables the communication again.

Parameter name (Index)	Subindex	Data structure	Data type
PO data description (6002 _{hex})	0	R	PBS(20 _{hex})

All process data are enabled when the device is switched on (6002_{hex} ≡ FFFFF_{hex})

7.6.7.2 Monitoring parameters

Process data monitoring time (6003_{hex})

If the transmission of the process data is inactive for longer than the set monitoring time (PCD watchdog), the action set in the parameter "process-data monitoring selection code" (6004_{hex}) will be activated.

Parameter name (Index)	Subindex	Data structure	Data type	Value range
Process data monitoring time (6003 _{hex})	0	S	OS-1 OS: Octet string, length: 4	0 - 65535 (Lenze setting: 65535 , monitoring is switched off)

Process data monitoring selection code (6004_{hex})

The parameter determines the reaction of the controller after the process data monitoring time is over (6003_{hex}).

Parameter name (Index)	Subindex	Data structure	Data type	Value range
Process data monitoring selection code (6004 _{hex})	0	S	I16	0 (Lenze setting), 0 = No action 2: Unit control command „Inhibit voltage“ (controller inhibit with latching in the status "SWITCH ON INHIBIT") 3: Unit control command "Quick stop" (quick stop (QSP) with latching in the status "SWITCH ON INHIBIT").

7.6.7.3 Error code (603F_{hex})

If the drive sets TRIP, the error code transmits an error number which corresponds to the DRIVECOM profile (see chapter 7.7.4 DRIVECOM error code).

A list of errors which occurred in Lenze controllers is stored under the Lenze parameters:

- 82XX: L-C0162 - L-C0164
- 93XX: L-C0168 with subindex 1 to 8

Parameter name (Index)	Subindex	Data structure	Data type
Error code (603F _{hex})	0	S	U16 OS

7.6.7.4 DRIVECOM control word (6040_{hex})

The controller is controlled via this parameter. It contains commands for the transition between different controller states (see chapter 7.6.6) and other important control commands (see the following table).

Parameter name (Index)	Subindex	Data structure	Data type
Control word (6040 _{hex})	0	S	0S

**Note!**

The bits contained in the control word are interdependent control commands which are to be parameterised. Chapter 7.6.6 describes the bits required to make the the command become effective.

Structure of the DRIVECOM control word

Bit	Name	Meaning
0	Switch on	Controller status 0 = command 2, 6, 8 (controller inhibit) 1 = command 3 (controller inhibit)
1	Voltage inhibit	Controller status 0 = command 9, 10, 12 (controller inhibit) 1 = command "voltage inhibit" not active
2	Quick stop	Controller status 0 = Command 7, 10, 11 (quick stop) 1 = Command "quick stop" not active
3	Operation enable	Controller status 0 = Command 5 (controller inhibit) 1 = Command 4 (controller inhibit not active)
4	RFG inhibit	Inhibit of the ramp-function generator. Quick stop is activated without the controller leaving its status. 0 = RFG inhibit (quick stop) 1 = RFG inhibit not active
5	FREE DRIVECOM: RFG-stop	820X: Not assigned
		821X, 822X: Output of the RFG (speed setpoint integrator) is "frozen". 0 = RFG stop 1 = RFG stop not active
		8200 vector, 93XX: Free. Mapping to bit AIF-CTRL.B4 negated.
6	FREE DRIVECOM: RFG-zero	820X: Not assigned
		821X, 822X: Ramp function generator input (speed setpoint integrator) = 0 (controlled deceleration along the set ramp) 0 = RFG zero 1 = RFG zero not active
		8200 vector, 93XX: Free. Mapping to bit AIF-CTRL.B5 negated.
7	Error reset	Fault reset (TRIP). For this, a bit change from 0 to 1 is required. For 82XX, the controller is initialised. During this time, the controller does not accept any commands.
8 - 10	Reserve	DRIVECOM reserved
11	FREE DRIVECOM: Manufacturer	820X, 821X, 822X: Not assigned
		8200 vector, 93XX: Free. Mapping to bit AIF-CTRL.B7.
12	FREE DRIVECOM: Manufacturer	820X, 821X, 822X: Parameter set changeover: 0 → 1 = Parameter set 2 1 → 0 = Parameter set 1
		8200 vector, 93XX: Free. Mapping to bit AIF-CTRL.B12.
13	FREE DRIVECOM: Manufacturer	820X, 821X, 822X: DC-injection brake: 0 = DCB not active 1 = DCB active
		8200 vector, 93XX: Free. Mapping to bit AIF-CTRL.B13 ¹⁾ .
14	FREE DRIVECOM: Manufacturer	820X, 821X, 822X: Not assigned
		8200 vector, 93XX: Free. Mapping to bit AIF-CTRL.B14.
15	FREE DRIVECOM: Manufacturer	8201X PE inhibit Inhibit the update of the PO data of the controller (input data for the master). Updates of status and current information of the process channel can be inhibited in order to send control information more precisely in time (see chapter 7.3.4.2). 0 = Read status and actual value 1 = Do not read status and actual value
		821X, 822X: Not assigned
		8200 vector, 93XX: Free. Mapping to bit AIF-CTRL.B15.

Link between DRIVECOM control word and AIF-CTRL control for 93XX and 9300 Servo PLC

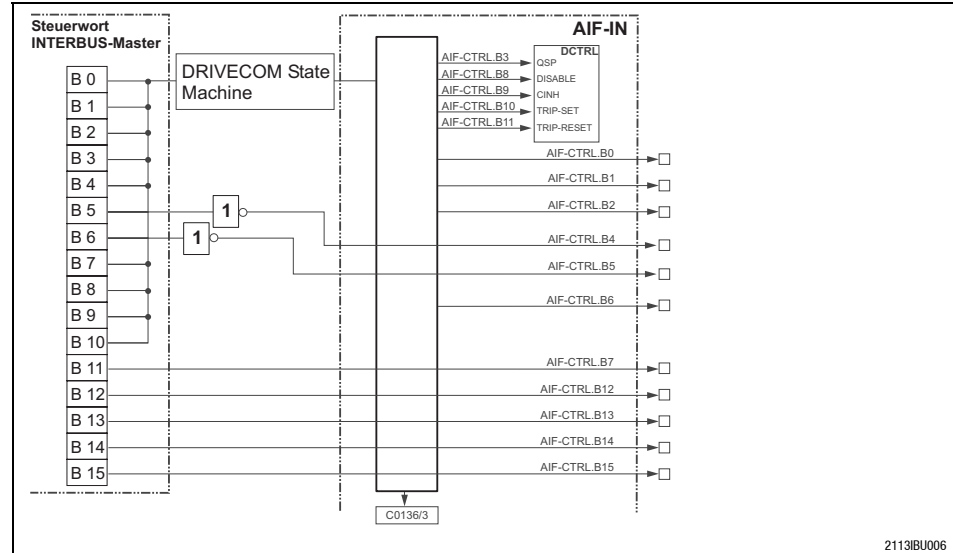

7.6.7.5 DRIVECOM status word (6041_{hex})

This parameter provides compact information about the controller. It contains commands for the transition between the different controller states (see chapter 7.6.6) and other important information (see the following table).



Note!

The current controller status can only be clarified by combining the bits with the status information (bit 0, 1, 2, 3, 4, 5 and 6). This is shown in chapter 7.6.6.

Parameter name (Index)	Subindex	Data structure	Data type
Status word (6041 _{hex})	0	S	0S

Structure of the DRIVECOM status word

Bit	Name	Meaning	
0	Ready to switch on	Controller status information 0 = Status lower than "READY TO SWITCH ON" 1 = Status at least "READY TO SWITCH ON"	
1	Switched on	Controller status information 0 = Status lower than "SWITCHED ON" 1 = Status at least "SWITCHED ON"	
2	Operation enabled	Controller status information 0 = Status lower than "OPERATION ENABLED" 1 = Status "OPERATION ENABLED"	
3	Fault	Controller status information 0 = No fault (TRIP) 1 = Fault (TRIP) occurred	
4	Voltage inhibited	Information about the command "voltage inhibit" (see chapter 7.6.7.4 "control word") 0 = Command active 1 = Command not active	
5	Quick stop	Information about the command "quick stop" (see chapter 7.6.7.4 "control word") 0 = Command active 1 = Command not active	
6	Switch-on inhibit	Controller status information 0 = Status not "SWITCH-ON INHIBIT" 1 = Status "SWITCH-ON INHIBIT"	
7	Warning	Collective warning 0 = No warning 1 = Warning (overtemperature)	
8	Meldung	Collective message. Automatic setting and resetting of pulse inhibit in the controller status "OPERATION ENABLED". Reasons for this can be undervoltage or overvoltage as well as overcurrent (clamp). 0 = No message 1 = Message (IMP)	
9	Remote	82XX, 821X, 822X, 8200 vector: 93XX:	Bus access, depends on Lenze parameter "operating mode" (L-C0001): 0 = L-C0001 < > 3 or L-C1911 = 0 1 = L-C0001 = 3 and L-C1911 = 1 0 = L-C1911 = 0 1 = L-C1911 = 1
10	FREE DRIVECOM: Setpoint reached	Status of speed/frequency deviation 0 = $RFG_{on} < > RFG_{off}$ 1 = $RFG_{on} = RFG_{off}$	
11	Limit value	Status of the DRIVECOM speed limitation 0 = Limitation not addressed 1 = Limitation addressed	
12	FREE DRIVECOM: Reserve	820X, 821X, 822X: 8200 vector, 93XX:	Not assigned Free. Mapping to bit L-C0150.B14
13	FREE DRIVECOM: Reserve	82XX: 8200 vector: 93XX:	Not assigned Free. Mapping to bit L-C0150.B15 Free. Mapping to bit L-C0150.B3
14	Manufacturer	820X, 821X, 822X: 8200 vector, 93XX:	I_{max} (current limit reached) 0 = Current limit not reached 1 = Current limit exceeded Free. Mapping to bit L-C0150.B2
15	Manufacturer	820X, 821X, 822X: 8200 vector, 93XX:	Q_{min} ($f_d \leq f_{dQmin}$) 0 = Q_{min} not active 1 = Q_{min} active Free. Mapping to bit L-C0150.B5

Link between DRIVECOM status word and function block STAT for 93XX and 9300 Servo PLC

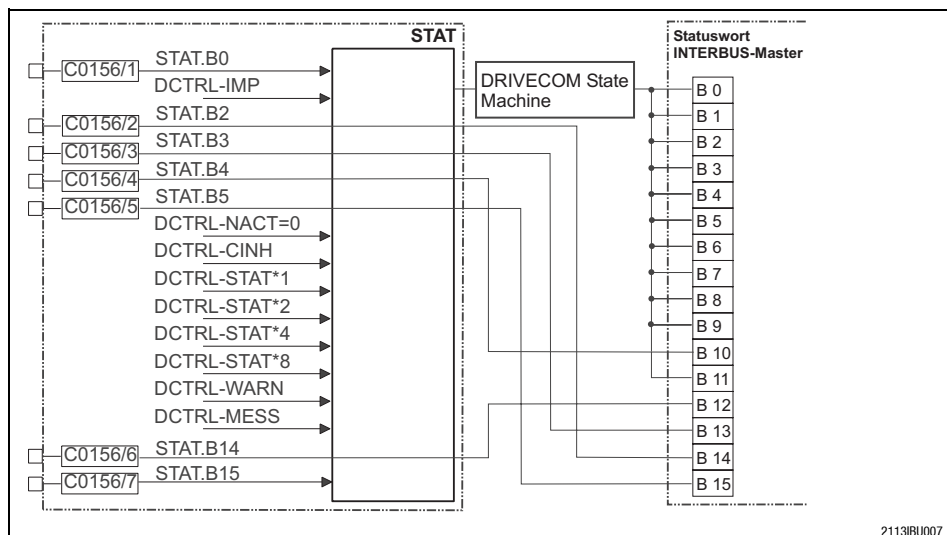

2113IBU007

7.6.7.6 Speed/velocity channel

Speed setpoint (6042_{hex})

The parameter sets the speed setpoint [rev/min]. If this parameter is changed, also the nominal percentage will be changed.

Parameter name (Index)	Subindex	Data structure	Data type	Value range
Speed setpoint (6042 _{hex})	0	S	I16	– 32768 to 32767

Speed reference variable (6043_{hex})

This parameter is the output value of the speed ramp function generator [rev/min].

Parameter name (Index)	Subindex	Data structure	Data type	Value range
Speed reference variable (6043 _{hex})	0	S	I16	– 32768 to 32767

Actual speed value (6044_{hex})

The parameter indicates the actual speed (in rpm).

Parameter name (Index)	Subindex	Data structure	Data type	Value range
Actual speed (6044 _{hex})	0	S	I16	– 32768 to 32767

Min/max speed value (6046_{hex})

This parameter indicates the minimum and the maximum speed (in rpm). It is initialised with the Lenze parameter L-C0011. Changing this parameter does not result in a change of L-C0011 (see "Speed-reference value").

Parameter name (Index)	Subindex	Data structure	Data type	Value range
Min/max speed value (6046 _{hex})	1	A	U32	0 to 32000 0: Minimum speed setpoint [rev/min]
	2	A	U32	0 to 32000 L-C0011: Maximum speed setpoint [rev/min]

Setpoint factor (604B_{hex})

This parameter is used to change the resolution or the setting range of the setpoint input. It consists of numerator and denominator. The setpoint is multiplied by the setpoint factor; the actual values (reference variable, actual value) are multiplied by the inverse setpoint factor.

Parameter name (Index)	Subindex	Data structure	Data type	Value range
Setpoint factor (604B _{hex})	1	A	I16	– 32768 to 32767 Lenze setting: 1 (Numerator of the "Setpoint factor")
	2	A	I16	– 32768 to 32767 Lenze setting: 1 (Denominator of the "Setpoint factor")

Data transfer

DRIVECOM profile parameters

Pole number (604D_{hex})

The parameter indicates the pole number of asynchronous motors and is used to convert frequency values into speed values. Only even values are possible.

Parameter name (Index)	Subindex	Data structure	Data type	Value range
Pole number (604D _{hex})	0	S	U8	2, 4, 6, ..., 254 Lenze setting: 4

Speed reference value (604E_{hex})

This parameter is the reference value for the relative speed parameters, e.g. nominal percentage, actual percentage and acceleration time. The parameter is mapped to the Lenze parameter L-C0011. A conversion to frequency values is possible. The parameter determines the internal maximum speed, which is also active with terminal control.

Parameter name (Index)	Subindex	Data structure	Data type	Meaning
Speed reference value (604E _{hex})	0	S	U32	$\frac{\text{L-C0011}}{2}$ in [rev/min]

Percentage setpoint (6052_{hex})

This parameter is the nominal speed in percent. It is scaled to the "speed reference value" (= 100 %). When changing this parameter, also the "nominal speed" will be changed. If the "nominal speed" exceeds the limit value of the "nominal percentage" of 200 % during reading, it will be returned as a value limited to 200 %.

Parameter name (Index)	Subindex	Data structure	Data type	Value range
Percentage setpoint (6052 _{hex})	0	S	I16	- 32768 to 32767 (100 % = 16383)

Percentage reference variable (6053_{hex})

This parameter is the "speed reference variable" in percent. It is scaled to the "speed reference value" (= 100 %). The "percentage reference variable" is multiplied by the inverse "setpoint factor".

Parameter name (Index)	Subindex	Data structure	Data type	Value range
Percentage reference variable (6053 _{hex})	0	S	I16	- 32768 to 32767 (100 % = 16383)

Actual percentage (6054_{hex})

This parameter is the "actual speed" in percent. It is scaled to the "speed reference value".

Parameter name (Index)	Subindex	Data structure	Data type	Value range
Actual percentage (6054 _{hex})	0	S	I16	- 32768 to 32767 (100 % = 16383) Map of L-C0381

7.6.7.7 Ramps

The DRIVECOM profile 21 provides two ramps for the speed setpoint:

- The **absolute ramp** is determined by the following ramp gradient:

$$\text{Gradient} = \frac{\text{Delta_speed}}{\text{Delta_time}}$$

The absolute ramps in the DRIVECOM profile 21 are "acceleration", "deceleration" and "quick stop".

- The **relative ramp** is determined by the following ramp gradient:

$$\text{Gradient} = \frac{\text{Speed reference value}}{\text{Delta_time}}$$

This definition corresponds to the Lenze ramp functions L-C0012 and L-C0013. The relative ramps in the DRIVECOM profile 21 are "acceleration time", "deceleration time" and "quick-stop time".

The "ramp-min function" determines and activates the slower ramp. The absolute ramps are deactivated in Lenze setting.

Speed ramps fro acceleration
(6048_{hex})

This parameter contains data of the absolute speed ramp for acceleration.

Ramp gradient:

$$\text{Gradient} = \frac{\text{Delta_speed}}{\text{Delta_time}}$$

The parameter is mapped to the Lenze acceleration ramp (L-C0012) via the "ramp-min-function".

"Delta_time" = 0: Ramp is switched off.

Parameter name (Index)	Subindex	Data structure	Data type	Value range
Speed acceleration (6048 _{hex})	1	RS (21 _{hex})	U32	0 to 4294967295 0: Delta_speed [rev/min]
	2	RS (21 _{hex})	U16	0 to 65535 0 (ramp is switched off): Delta_time [sec]

The "ramp-min function" determines and activates the slower ramp. The absolute ramps are deactivated in Lenze setting.

Speed ramps for deceleration
(6049_{hex})

This parameter contains data of the absolute speed ramp for deceleration.

Ramp gradient:

$$\text{Gradient} = \frac{\text{Delta_speed}}{\text{Delta_time}}$$

The parameter is mapped to the Lenze deceleration ramp (L-C0013) via the "ramp-min-function". If the "delta_time" = 0, the ramp is switched off.

Parameter name (Index)	Subindex	Data structure	Data type	Value range
Speed delay (6049 _{hex})	1	RS (21 _{hex})	U32	0 to 4294967295 0 : Delta_speed [rev/min]
	2	RS (21 _{hex})	U16	0 to 65535 0 (ramp is switched off) : Delta_time [sec]

Speed quick stop (604A_{hex})

This parameter contains the data of the absolute speed ramp for deceleration in the status "QUICKSTOP" or "CTRL INHIBIT" or the QSP terminal function.

Ramp gradient:

$$\text{Gradient} = \frac{\text{Delta_speed}}{\text{Delta_time}}$$

The parameter is mapped to the Lenze quick-stop ramp (L-C0105) via the "ramp-min-function". If the "delta_time" = 0, the ramp is switched off.

Parameter name (Index)	Subindex	Data structure	Data type	Value range
Quick stop (604A _{hex})	1	RS (21 _{hex})	U32	0 to 4294967295 0 : Delta_speed [rev/min]
	2	RS (21 _{hex})	U16	0 to 65535 0 (ramp is switched off) : Delta_time [sec]

Acceleration time (604F_{hex})

This parameter is for the acceleration of the relative speed ramp. The acceleration time refers to the parameter "speed reference" with the following slope:

Ramp gradient:

$$\text{Gradient} = \frac{\text{Speed reference value (604E}_{\text{hex}})}{\text{Acceleration time (604F}_{\text{hex}})}$$

The parameter is mapped to the Lenze acceleration ramp (L-C0012) via the "ramp-min-function". If the "acceleration time" = 0, the ramp is switched off.

Parameter name (Index)	Subindex	Data structure	Data type	Value range
Acceleration time (604F _{hex})	0	S	U32	0 to 495000 [ms] (max. L-C0012 / 2)

Deceleration time (6050_{hex})

This parameter is for the deceleration of the relative speed ramp. The deceleration time refers to the parameter "Speed reference value".

Ramp gradient:

$$\text{Gradient} = \frac{\text{Speed reference value (604E}_{\text{hex}})}{\text{Deceleration time (6050}_{\text{hex}})}$$

The parameter is mapped to the Lenze deceleration ramp (L-C0013) via the "ramp-min-function". If the „deceleration time“ = 0, the ramp is switched off.

Parameter name (Index)	Subindex	Data structure	Data type	Value range
Deceleration time (6050 _{hex})	0	S	U32	0 to 495000 [ms] (max. L-C0013 / 2)

Quick-stop time (6051_{hex})

This parameter is assigned to the relative speed ramp for the unit-control commands "quick stop" and "CTRL inhibit" or the QSP terminal function. The quick stop time refers to the parameter "Speed reference value".

Ramp gradient:

$$\text{Gradient} = \frac{\text{Speed reference value (604E}_{\text{hex}})}{\text{Quick stop time (6051}_{\text{hex}})}$$

The parameter is mapped to the Lenze quick-stop ramp (L-C0105) via the "ramp-min-function". If the "quick stop time" = 0, the ramp is switched off.

Parameter name (Index)	Subindex	Data structure	Data type	Value range
Quick-stop time (6051 _{hex})	0	S	U32	0 to 495000 [ms] (max. L-C0105 / 2)

7.6.8 Configuration of the parameter data channel (PCP communication)

7.6.8.1 General information

Access to controller codes

The behaviour and features of a device connected to the INTERBUS can be changed through the INTERBUS master. The device is connected via the attached fieldbus module. All devices (☐ 7.2-1) can be connected to the bus.

Features and behaviour can be changed by changing the parameter data of the basic unit. Parameter data are

- Lenze parameters (L- Cxxxx)
 - Lenze parameters are implemented in Lenze controllers or fieldbus modules.
 - In these descriptions Lenze parameters are marked by an L followed by the code as indicated in the corresponding controller description (“C” and 4-digit code number).
- DRIVECOM parameters
 - For more all manufacturers
 - Normalisation in DRIVECOM profile 21
 - Every DRIVECOM parameter is addressed by the corresponding index (overview in chapter 7.8.1.3).

Lenze controllers store the parameters to be changed incodes.



Note!

These Instructions use a "L-Cxxxx" in front of a code to indicate that it is a Lenze code and not a DRIVECOM index.
Example: 'L-C0001' stands for the Lenze code C0001.

Controller codes are addressed via the index when they are accessed through the bus module.

The index for Lenze code numbers is between 16576 (40C0_{hex}) and 24575 (5FFF_{hex}).

Conversion formula:

$$Index[dec] = 24575 - Lenze\ code$$

Example for operating mode L-C0001:

dec	hex
Index = 24575 - LENZE CODENO	Index _{hex} = 5FFF _{hex} - LENZE-CODENO _{hex}
Index = 24574 (= 24575 - 1)	Index _{hex} = 5FFE _{hex} (= 5FFF _{hex} - 1)

Value range for Lenze parameters

The value range for Lenze codes can be found in the Operating Instructions for the corresponding controller (see: Code table).

The data of the Lenze parameters are mainly represented in a fixed-point format of the data type Integer32 with four decimal digits. This means, that the parameter value listed in the Operating Instructions must be multiplied by 10000.

Example:

	dec	hex
L-C0039 (JOG) = 150.4 Hz	150.4 x 10000 = 1504000	= 0016F300

Configuration of the parameter data channel (PCP communication)**Lenze parameter sets**

Parameter sets are for special code saving which is necessary because of different configurations for different application processes.

The following table informs about number and addressing of parameter sets for your controller:

82XX	8200 vector	93XX
The 82XX and 8200 vector have 2 and 4 parameter sets. The parameters can be directly addressed via INTERBUS. They are addressed by means of a code-digit offset:		93XX controllers have 4 parameter sets (depending on the variant). They are saved in the EEPROM of the controller.
<ul style="list-style-type: none"> • Offset 0 addresses parameter set 1 with the Lenze codes L-C0000 to L-C1999 • Offset 2000 addresses parameter set 2 with the Lenze codes L-C2000 to L-C3999 	<ul style="list-style-type: none"> • Offset 4000 addresses parameter set 3 with the Lenze codes L-C4000 to L-C5999 • Offset 6000 addresses parameter set 4 with the Lenze codes L-C6000 to L-C7999 	Another parameter set is in the user memory of the controller. This parameter set can be changed by the user. <ul style="list-style-type: none"> • After switch-on parameter set 1 is <u>automatically</u> loaded as <u>current</u> parameter set. • Parameter sets 2 - 4 must be loaded <u>manually</u> to the RAM.
No additional parameter sets available.		→ Only the parameter set directly stored in the RAM can be addressed via INTERBUS.
If a parameter is available only once (see Operating Instructions for 82XX or 8200 vector), use the code digit offset 0.		
Example for L-C0011 (maximum field frequency): L-C0011 in parameter set 1: Lenze code = 11 L-C0011 in parameter set 2: Lenze code = 2011		
	L-C0011 in parameter set 3: Lenze code = 4011 L-C0011 in parameter set 4: Lenze code = 6011	
Parameter changes		
Automatic saving in the controller	Automatic saving is default setting (changeable under L-C0003)	Changes must be stored in code L-C0003. All changes made without storing them will be lost after the controller is switched off.
Process data changes		
No automatic saving	No automatic saving	No automatic saving

**Stop!**

- For 8200 vector
 - Please observe that cyclic writing of parameter data into the EEPROM is not permissible.
 - Please configure the code to C0003 = 0 after each mains disconnection if you want to change the parameter data cyclically.
- For 82XX
 - Please observe that cyclic writing of parameter data into the EEPROM is not permissible.

7.6.8.2 Initialisation of PCP communication

CRL entries

CRL (Communication Reference List) entries are required to ensure communication between the INTERBUS master and the fieldbus module.

The following entries are to be set in the INTERBUS-master CRL:

Field name	Entry
Communication reference (CR)	2
Connection type	Acyclic master/slave
Connection attribute	Defined
Max PDU sending high prio	0
Max PDU sending low prio	64
Max PDU receiving high prio	0
Max PDU receiving low prio	64
Supported service request	80 30 00 _{hex}
Supported Services Response	00 00 00 _{hex}
Maximum SCC	1
Maximum RCC	1
Maximum SAC	1
Maximum RAC	1

7.6.8.3 Available PCP services

In the following, you will find all the parameters and their contents which are returned by Lenze controllers. All other transmission parameters of the stated PCP services can be obtained from the corresponding INTERBUS master description.

Parameters are transmitted via the PCP channel (PCP = Peripherals Communication Protocol). This is carried out via PCP services.

The following PCP services are supported by Lenze controllers:

- Initiate: Build up connection between INTERBUS master and controller (☞ 7.6-50)
- Abort: Disconnect (☞ 7.6-50)
- Read: Read parameters (☞ 7.6-50)
- Write: Write parameters (☞ 7.6-50)
- Get-OV: Read object directory (OV) (☞ 7.6-51)
- Identify: Identification of controller (☞ 7.6-51)
- Status: Read controller status (☞ 7.6-52)

Configuration of the parameter data channel (PCP communication)**Initiate**

The PCP service "Initiate" creates a logic between the INTERBUS master and the fieldbus module. The controller returns the following parameters:

Name	Value	Meaning
Profile number	21 _{hex}	DRIVECOM profile of version 1
Password	0	Password function of INTERBUS not supported
Access groups	0	No access groups
Access protection supported	TRUE	Access protection is supported
Version OV	0	Version of the object directory

Abort

The PCP service "Abort" interrupts a logic between the INTERBUS master and the fieldbus module.

Read and write

The PCP service "Read" reads parameters from the controller. The controller transmits the required parameter or a fault message.

The PCP service "Write" writes controller parameters. The controller transmits a positive or negative acknowledgement or a fault message.

The following fault messages can occur:

Error class	Error code	Additional code	Meaning
6	3	00 _{hex}	No access
6	5	10 _{hex}	Invalid service parameter
6	5	11 _{hex}	Invalid subindex
6	5	12 _{hex}	Data too long
6	5	13 _{hex}	Data too short
6	6	00 _{hex}	Object is not a parameter
6	7	00 _{hex}	Object does not exist
6	8	00 _{hex}	Data types are not identical
8	0	00 _{hex}	Service cannot be executed
8	0	20 _{hex}	Service cannot be executed currently
8	0	21 _{hex}	Cannot be executed because of local control
8	0	22 _{hex}	Cannot be executed because of unit status
8	0	30 _{hex}	Leave value range/parameter can only be changed while controller is inhibited
8	0	31 _{hex}	Parameter value too high
8	0	32 _{hex}	Parameter value too small
8	0	33 _{hex}	Subparameter out of value range
8	0	34 _{hex}	Subparameter value too high
8	0	35 _{hex}	Subparameter value too small
8	0	36 _{hex}	Maximum value smaller than minimum value
8	0	41 _{hex}	Communication object cannot be mapped to process data
8	0	42 _{hex}	Process-data length exceeded
8	0	43 _{hex}	Collision with other values

Get-OV

The PCP service "Get-OV" reads the object description for each parameter and data type.

Identify

The PCP service "Identify" informs about the controller identification. The controller returns the following parameters:

Name	Value	Meaning
Name of the manufacturer	"Lenze" (as visible string)	Company name
Controller name	Visible string with 15 characters	Unit name for controller and bus-interface module
Controller version	Visible string with 15 characters	Software version of the controller

Controller name

The visible string consists of the following characters:

- Characters 1 to 5: Name of the controller (4 characters for the controller name plus 1 blank)
- Characters 6 to 10: Name of the fieldbus module (4 characters for the controller name plus 1 blank)
- Characters 11 to 15: No name (5 blanks)

If a fieldbus module is not available, the corresponding area will be filled with blanks.

Example:

8200 vector controller with 2113 fieldbus module: "8212 2113"

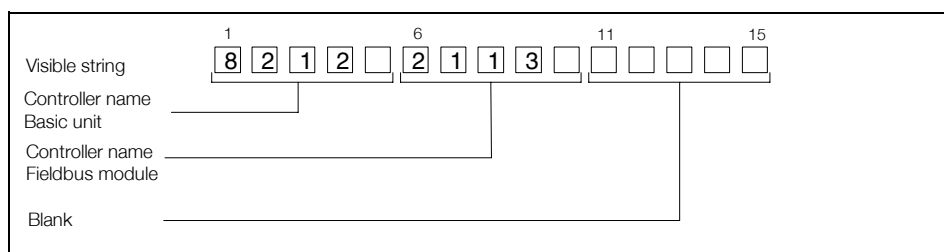

Controller version

The visible string consists of the following characters:

- Characters 1 to 5: software version of the controller:
 - 2 characters for the basic version
 - 2 characters for the variant
 - 1 character for the version of the variant
- Characters 6 to 10: software version of the fieldbus module
 - 2 characters for the basic version
 - 2 characters for the variant
 - 1 character for the version of the variant
- Characters 11 to 15: No name
 - 5 blanks

Configuration of the parameter data channel (PCP communication)

Example:

For a 8200 controller 8201 (version V2.1; without variant and variant version) with fieldbus module (version V1.0; without variant and variant version): "2100010000"

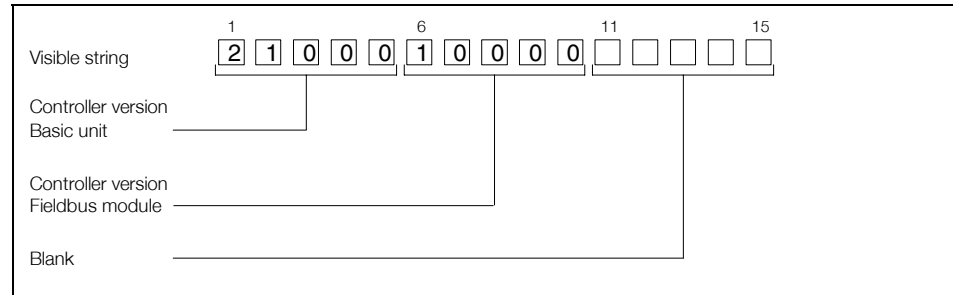

Status

The PCP service "Status" informs about the controller status.

The controller returns the following parameters:

Status	Value	Meaning
Logical status	0 = ready to communicate	Information about the current operating mode (L-C0001) of the controller concerning communication
Physical status	<ul style="list-style-type: none"> 0 = ready for operation Controller status "OPERATION ENABLED" 1 = partly ready for operation All other controller states 	Information about the current operating state of the controller. For the controller status see 7.6-30.
Local detail	Parameter "Status word"	24-bit value comprising: <ul style="list-style-type: none"> Bit 0 to 15: Profile parameter "Status word" (Index = 6041_{hex}) Bit 16 to 23: value 0

7.7 Troubleshooting

7.7.1 Controller is inhibited

The controller cannot be enabled via INTERBUS process data, i.e. the status "OPERATION ENABLED" will not be reached.

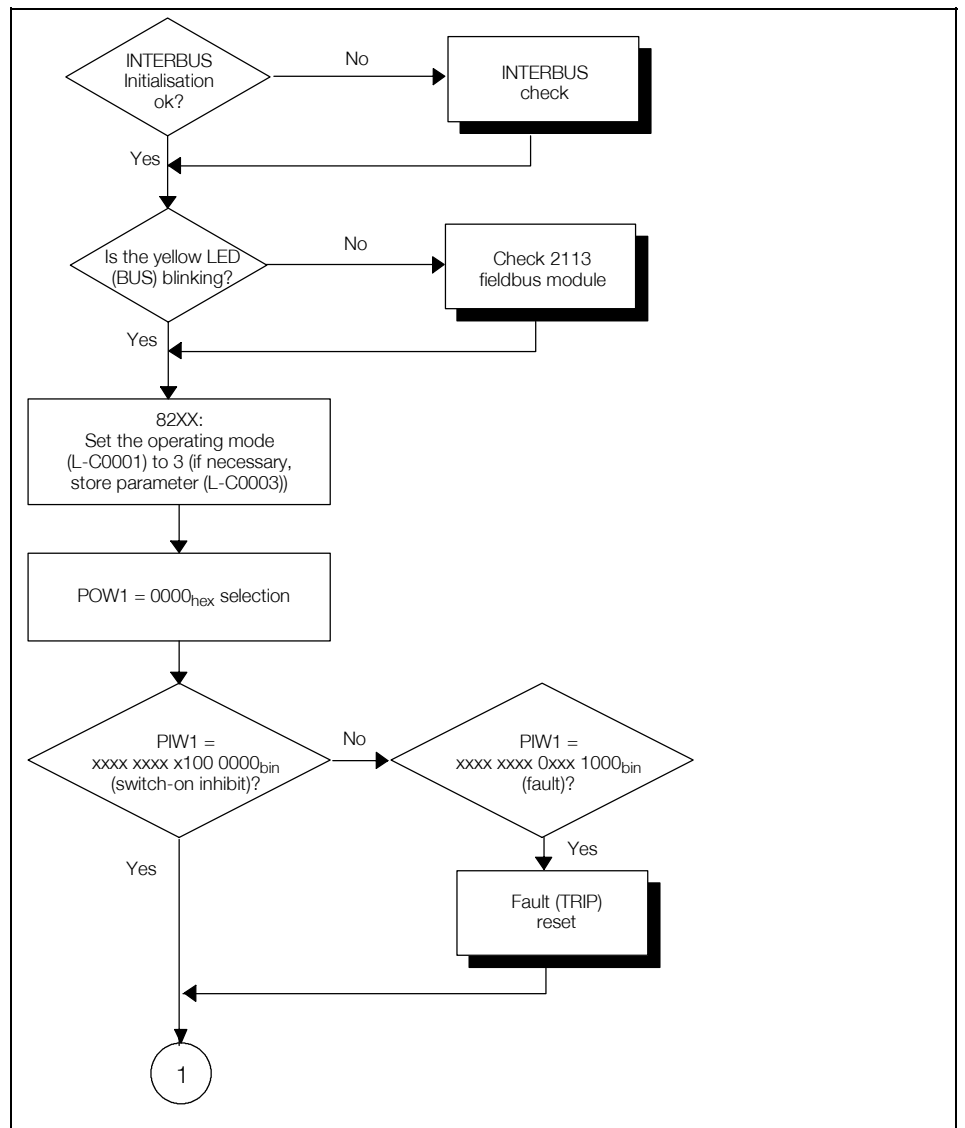

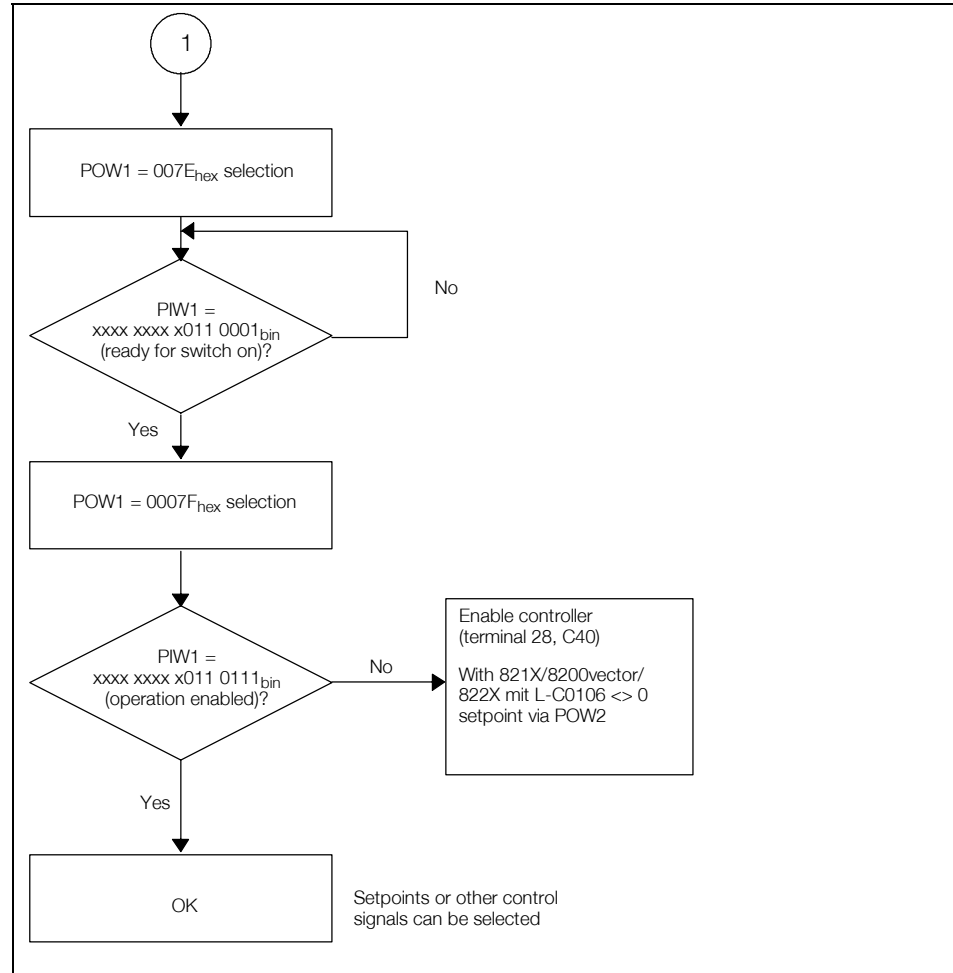

7.7.2 Check INTERBUS

Short test of the INTERBUS system in the event of faulty initialisation. The diagnostics information of the INTERBUS fieldbus modules must be considered by the INTERBUS master.

For troubleshooting it can be useful to reduce the bus so that only one unit is connected to the INTERBUS.

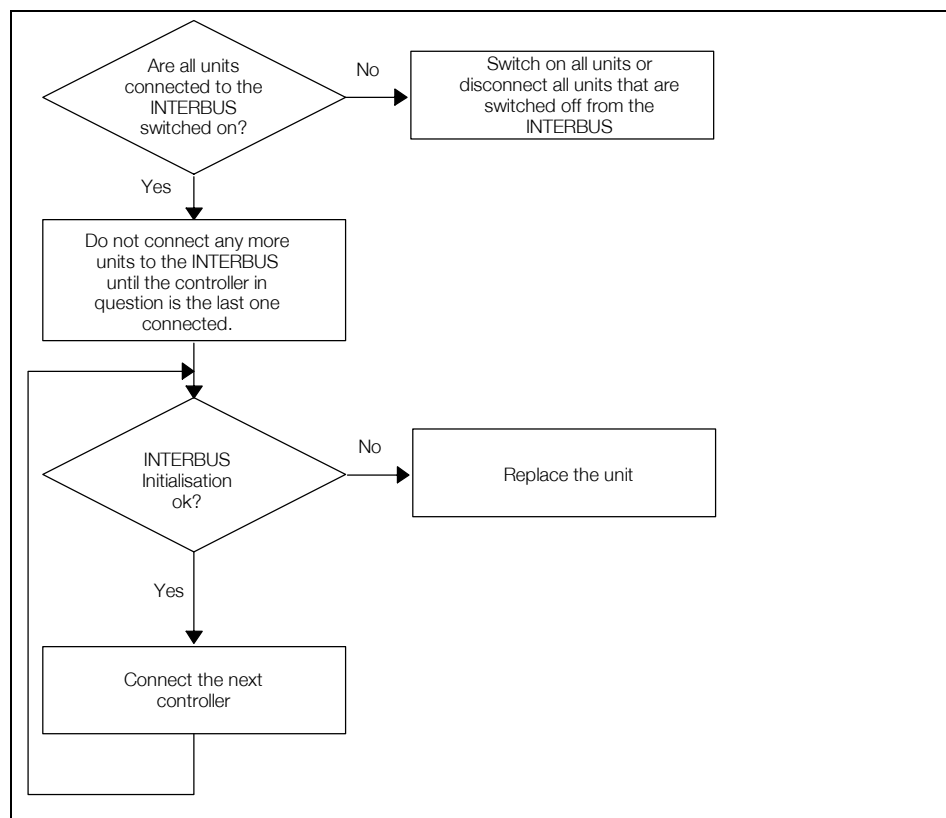

7.7.3 Reset error (TRIP)

Error reset via INTERBUS process data.

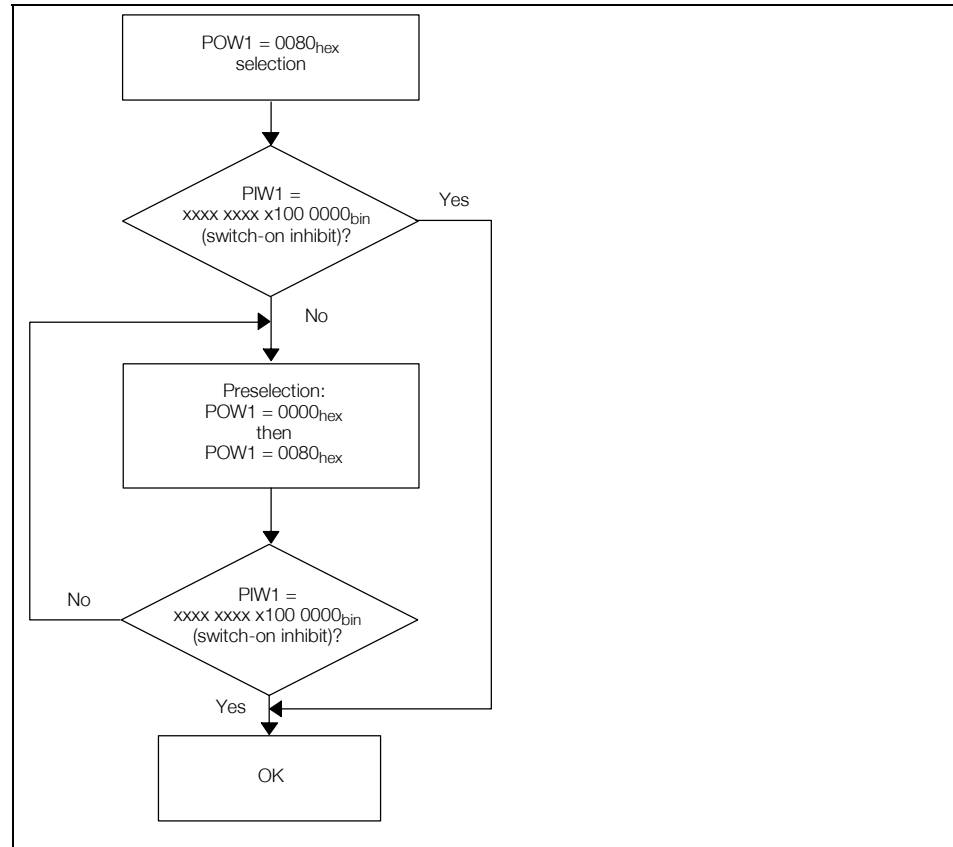

7.7.4 DRIVECOM error codes

DRIVECOM fault codes, which can be generated at present:

Lenze error abbreviation	Lenze error no.	DRIVECOM error code [hex]	Meaning
	0	0	No error
OC3	13	2213	Overcurrent during acceleration
OC4	14	2214	Overcurrent during deceleration
OC	10	2300	Overcurrent
OC5	15	2311	I*t monitoring
OC7	17	2311	I*t –monitoring limit 2
OC6	16	2312	I2t monitoring
OC1	11	2320	Short circuit, overload
OC2	12	2330	Earth fault
OU	20	3000	Overvoltage (operating status)
LP1	32/182	3130	Phase failure
US1	40	3140	Mains frequency error
US3	42	3141	Mains frequency too high
US2	41	3142	Mains frequency too low
OUE	22	3212	Overvoltage error
OH51	203	4000	PTC overtemperature
OH / OH2/4	50/52/54	4210	Heatsink overtemperature
OH3/7/8	53/57/58	4310	Motor overtemperature
OH1	51	4410	Supply module overtemperature
H08	108	5000	Hardware error
U15	70	5111	Vcc15 supply interrupted
H07	107	5200	Power stage detection
H10	110	5210	Heatsink temperature sensor error
H11	111	5210	Inside temperature sensor error
RST	76	6000	Auto-Trip-Reset error
H05	105	6000	Version error
CCr	71	6010	System error
Per/Pr5	74/79	6100	Program error
	201-219	6200	Overrun or float error
	230	6200	No PLC program
	231	6200	LenzeXXX.lib not supported
P17	167	6200	TP control error
	220	6300	No technology unit
Pr0	75	6300	Gen. parameter set error
Pr1	72	6301	Parameter set 1 error
Pr2	73	6302	Parameter set 2 error
Pr3	77	6303	Parameter set 3 error
Pr4	78	6304	Parameter set 4 error
Id1	140	6320	Faulty parameter identification
Sd5-8	85-88	7300	Setpoint encoder
PTs	81	7301	Analog encoder defective
Pr6	80	7302	Wrong encoder polarity
Sd2	82	7303	Open circuit at resolver
Sd3	83	7305	Incremental encoder 1
Sd4	84	7306	Incremental encoder 2
P09	159	8000	Error code monitoring

Lenze error abbreviation	Lenze error no.	DRIVECOM error code [hex]	Meaning
CE0	61	8100	AIF time monitoring
CE1.4 CE11-14	62-65 122-125	8100	CAN time monitoring
CE5	66	8100	CAN time OUT
P16	166	8100	Sync telegram transmission error
	240	8100	Free CAN obj. send memory overflow
	241	8100	Free CAN obj. too many telegrams received
P18	168	8200	Internal limitation
NMAX	200	8400	Nmax system speed
P04	154	8500	Negative position error
P05	155	8500	Positive position error
P06	156	8500	Home position not known
P07	157	8500	Absolute program set mode
P08	158	8500	Act. home position exceeding position limits
P12	162	8500	Encoder area error
P13	163	8500	Angle overrun
P03,14,15	153/164-165	8611	Contouring error
P21	171	8611	RC contouring error
P01	151	8612	Limit-stop switch negative
P02	152	8612	Limit-stop switch positive
EEr	91	9000	External trip

**Note!**

Only faults and errors caused by the controller can occur.
Please read the Operating Instructions for the controller.

7.8 Appendix

7.8.1 Code table

7.8.1.1 Codes of the 2113 INTERBUS fieldbus module

Software codes

These codes determine the software used. Software version and date can be read.

Code	Values	Lenze setting	Explanation
L-C1810	33S2113L_x y000		Software registration number for 2113
L-C1811			Software creation date [mmm tt jjjj] hh:mm:ss]

Process data length

Here you can enter the number of transferred process data words in bytes if all DIP switches are "OFF". The setting under this code is only active then.

The number of process data can have up to 20 bytes. L-C1910 can be overwritten with values from 2 to 20. A value of 5 is internally rounded off to 4. The value is saved in the EEPROM of the 2113 fieldbus module. The change of the process-data length is only effective after the next basic initialisation of the 2113 fieldbus module, i.e. after switching the voltage supply off and on again.

A value higher than 4 bytes should only be used for 93XX and 8200 vector since only here the data can be passed on. However, a length of > 4 bytes is possible with 82XX. Values > 6 bytes should only be used for controllers of the 9300 Servo PLC and Drive PLC series.

Code	Values	Lenze setting	Explanation
L-C1910	2 - 20	4	INTERBUS process data length in bytes

Unit or DRIVECOM control

Here you can set the unit or DRIVECOM control if all DIP switches are "OFF". The setting is only active then.

Code	Values	Lenze setting	Explanation
L-C1911	0/1	1	<ul style="list-style-type: none"> • 1: The control word is transmitted from the INTERBUS master to the controller via the DRIVECOM status machine. • 0: The AIF-CTRL control word is active.

Parameter data words

This code contains the number of parameter data words (PCP). The value is active and can be changed if all DIP switches are "OFF".

Code	Values	Lenze setting	Explanation
L-C1912	0/1/2/4	1	Read/write number of parameter data words (PCP)

Indication of current switch position

These codes contain all current switch positions. They can only be indicated!

Code	Values	Lenze setting	Explanation
L-C1915	0 - 10		Display of current switch positions S1 ... S4, set process data word length PD
L-C1916	0/1		Display of the current switch position S7, device control or DRIVECOM control
L-C1917	0/1/2/4		Display of the current switch position S5 and S6, set parameter data word length

7.8.1.2 Controller codes

Code	Values	Lenze setting	Explanation
L-C0001			Operating mode
			Control source
	0		Terminal
	1		Terminal
	2		Terminal
	3		INTERBUS
			Setpoint source
			Terminal
			8201BB
			Terminal
			INTERBUS
			Parameter source
			INTERBUS
			INTERBUS (operating module)
			INTERBUS
			INTERBUS
L-C0009	Process data preconfiguration  Please see the notes in chapter 7.8.2		
L-C0142			<p>This parameter L-C0142 prevents the drive from uncontrolled restarts after:</p> <ul style="list-style-type: none"> • Mains switching • Internal fault • Internal message (with pulse inhibit) > 0.5 s <p>If the controller sets the status "message" because of a failure (e.g. short mains failure) and the fault remains active for longer than 0.5 s, controller inhibit will be set automatically.</p> <p>The parameter L-C0142 has the following function:</p> <ul style="list-style-type: none"> • L-C0142 = 1: The drives will restart automatically as soon as the error has been eliminated. • L-C0142 = 0: The controller remains inhibited and the drive cannot restart even if the error has been eliminated. <ul style="list-style-type: none"> – The drive restarts after a LOW-HIGH transition at one of the inputs for "controller inhibit" (CINH, e.g. at terminal X5/28) wieder an

All codes are described in detail in the corresponding Operating Instructions.

7.8.1.3 Code table for the DRIVECOM profile 21

Explanation of the following code tables:

Name	Meaning
R/W	Write/read authorization via LECOM
	Ra = only read access permitted Ra/W= Read access always permitted, write access permitted under certain conditions (e.g. depending on Lenze parameter L-C0001 (operating mode) or controller status)
PD	Mapping to INTERBUS process data (index 6010 _{hex} , 6011 _{hex})
	PI = Process input data (from the controller to the host)
	PO= Process output data (from the host to the controller)
	POI= Process input and output data (see PO and PI)
- = Mapping of the process data not possible	
SP	Non-volatile saving of the parameter
	y = Yes Parameter will be saved
	n = No Parameter will not be saved
- = Parameter depends on the process and will therefore not be saved	
Data str.	Data structure
	S = Simple variable The parameter consists of one value and can only be addressed via subindex 0.
	A = Array variable (field parameter) The parameter contains several values of the same data type. The individual elements can be directly addressed by means of the subindex. Subindex = 0 addresses the whole parameter contents.
R = Record variable (combined parameter) The parameter contains several values of different data types. Subindex = 0 addresses the whole parameter contents.	
Data type	Data type
	BOL = Boolean FALSE = 00 _{hex} ; TRUE = FF _{hex}
	I8 = Integer8 -128 ≤ x ≤ 127
	I16 = Integer16 -32768 ≤ x ≤ 32767
	I32 = Integer32 -2147483648 ≤ x ≤ 2147483647
	U8 = Unsigned8 0 ≤ x ≤ 255
	U16 = Unsigned16 0 ≤ x ≤ 65535
	U32 = Unsigned32 0 ≤ x ≤ 4294967295
	OS = Octet string 8 bit/byte [= 1 byte or 8 bit per byte] binary coded
	VS = Visible string; text coded to ISO 646
	PDS = Process data description structure (index 20 _{hex})
RS = Ramp structure (index 21 _{hex}) Subindex 1: U32, numerator "delta_speed" in rev/min Subindex 2: U16, denominator "delta_time" in seconds	
Data number	Display of the parameter elements
Data length	Total length of the parameter in byte

According to the standardization of controller parameters according to the DRIVECOM profile 21 the following parameters are implemented:

Index hex	Index dec	Parameter name	R/W	PD	SP	Data str.	Data type	Data number	Data length
6000	24576	Process-input data description	Ra/W	-	Y	R	PDS	≤ 41	≤ 61
6001	24577	Process-output data description	Ra/W	-	Y	R	PDS	≤ 41	≤ 61
6002	24578	Process-output data - release	Ra/W	-	n	S	OS	4	4
6003	24579	Process data monitoring time	Ra/W	-	Y	S	U16	1	2
6004	24580	Process-data - selection code	Ra/W	-	Y	S	I16	1	2
603F	24639	Error code	Ra	-	n	S	OS	1	2
6040	24640	Control word	Ra/W	POI	-	S	OS	2	2
6041	24641	Status word	Ra	PE	-	S	OS	2	2
6042	24642	Speed setpoint	Ra/W	POI	-	S	I16	1	2
6043	24643	Master speed	Ra	-	-	S	I16	1	2
6044	24644	Actual speed	Ra	PE	-	S	I16	1	2
6046	24646	Speed - min./max. value	Ra/W	-	n	A	U32	2	8
6048	24648	Acceleration	Ra/W	-	n	R	RS	2	6
6049	24649	Deceleration	Ra/W	-	n	R	RS	2	6
604A	24650	Quick stop	Ra/W	-	n	R	RS	2	6
604B	24651	Setpoint factor	Ra/W	-	Y	A	I16	2	4
604D	24653	Pole number	Ra/W	-	Y	S	U8	1	1
604E	24654	Speed reference value	Ra/W	-	n	S	U32	1	4
604F	24655	Acceleration time	Ra/W	-	n	S	U32	1	4
6050	24656	Deceleration	Ra/W	-	n	S	U32	1	4
6051	24657	Quick stop time (not with 820X)	Ra/W	-	n	S	U32	1	4
6052	24658	Percentage setpoint	Ra/W	POI	-	S	I16	1	2
6053	24659	Master percentage	Ra	-	-	S	I16	1	2
6054	24660	Actual percentage	Ra	PE	-	S	I16	1	2

7.8.2 Parameter values of process data preconfiguration

7.8.2.1 PI-data

L-C0009	L-C1910 *)	L-C1911 *)	Index 6000, subindex:									
			2 / 3	6 / 7	10 / 11	14 / 15	18 / 19	22 / 23	26 / 27	30 / 31	34 / 35	38 / 39
11	40000	0	5F69 / 0	5CA5 / 1								
12		0	5CA5 / 1	5CA5 / 2								
13		0	5CA5 / 2	5CA5 / 3								
14		10000	6041 / 0	6044 / 0								
15		10000	6041 / 0	6054 / 0								
16		10000	6041 / 0	5CA5 / 1								
17		0	5F69 / 0	6044 / 0								
18		0	5F69 / 0	6054 / 0								
21	60000	10000	6041 / 0	6044 / 0	5CA5 / 2	5CA5 / 3	5CA5 / 4	5CA5 / 5	5CA5 / 6	5CA5 / 7	5CA5 / 8	5CA5 / 9
22		10000	6041 / 0	6054 / 0	5CA5 / 2	5CA5 / 3	5CA5 / 4	5CA5 / 5	5CA5 / 6	5CA5 / 7	5CA5 / 8	5CA5 / 9
23		10000	6041 / 0	5CA5 / 1	5CA5 / 2	5CA5 / 3	5CA5 / 4	5CA5 / 5	5CA5 / 6	5CA5 / 7	5CA5 / 8	5CA5 / 9
24		10000	6041 / 0	5CA5 / 2	5CA5 / 3	5CA5 / 4	5CA5 / 5	5CA5 / 6	5CA5 / 7	5CA5 / 8	5CA5 / 9	5CA5 / 10
25		0	5F69 / 0	5CA5 / 1	5CA5 / 2	5CA5 / 3	5CA5 / 4	5CA5 / 5	5CA5 / 6	5CA5 / 7	5CA5 / 8	5CA5 / 9
26		0	5F69 / 0	5CA5 / 2	5CA5 / 3	5CA5 / 4	5CA5 / 5	5CA5 / 6	5CA5 / 7	5CA5 / 8	5CA5 / 9	5CA5 / 10
27		60000	0	5CA5 / 1	5CA5 / 2	5CA5 / 3	5CA5 / 4	5CA5 / 5	5CA5 / 6	5CA5 / 7	5CA5 / 8	5CA5 / 9

*) This entry is only effective if switches S1 ... S7 = OFF.

Appendix

Parameter values of process data preconfiguration

7.8.2.2 PO-data

L-C0009	L-C1910 *)	L-C1911 *)	Index 6001, subindex:									
			2 / 3	6 / 7	10 / 11	14 / 15	18 / 19	22 / 23	26 / 27	30 / 31	34 / 35	38 / 39
11	4000	0	5F78 / 0	5CA7 / 1								
12	4000	0	5CA7 / 1	5CA7 / 2								
13	4000	0	5CA7 / 2	5CA7 / 3								
14	4000	10000	6040 / 0	6042 / 0								
15	4000	10000	6040 / 0	6052 / 0								
16	4000	10000	6040 / 0	5CA7 / 1								
17	4000	0	5F78 / 0	6042 / 0								
18	4000	0	5F78 / 0	6052 / 0								
21	6000	10000	6040 / 0	6042 / 0	5CA7 / 2	5CA7 / 3	5CA7 / 4	5CA7 / 5	5CA7 / 6	5CA7 / 7	5CA7 / 8	5CA7 / 9
22	6000	10000	6040 / 0	6052 / 0	5CA7 / 2	5CA7 / 3	5CA7 / 4	5CA7 / 5	5CA7 / 6	5CA7 / 7	5CA7 / 8	5CA7 / 9
23	6000	10000	6040 / 0	5CA7 / 1	5CA7 / 2	5CA7 / 3	5CA7 / 4	5CA7 / 5	5CA7 / 6	5CA7 / 7	5CA7 / 8	5CA7 / 9
24	6000	10000	6040 / 0	5CA7 / 2	5CA7 / 3	5CA7 / 4	5CA7 / 5	5CA7 / 6	5CA7 / 7	5CA7 / 8	5CA7 / 9	5CA7 / 10
25	6000	0	5F78 / 0	5CA7 / 1	5CA7 / 2	5CA7 / 3	5CA7 / 4	5CA7 / 5	5CA7 / 6	5CA7 / 7	5CA7 / 8	5CA7 / 9
26	6000	0	5F78 / 0	5CA7 / 2	5CA7 / 3	5CA7 / 4	5CA7 / 5	5CA7 / 6	5CA7 / 7	5CA7 / 8	5CA7 / 9	5CA7 / 10
27	6000	0	5CA7 / 1	5CA7 / 2	5CA7 / 3	5CA7 / 4	5CA7 / 5	5CA7 / 6	5CA7 / 7	5CA7 / 8	5CA7 / 9	5CA7 / 10

*) = This entry is only effective if switches S1 ... S7 = OFF.

7.9 Index

0 ... 9

2111 fieldbus module, Matching settings, 7.5-5

2113 INTERBUS fieldbus module, 7.1-1

8200 vector, Status word, 7.6-12

82XX, Status word, 7.6-8

93XX

- Control word, 7.6-19

- Status word, 7.6-17

A

Abort, 7.6-50

Appendix, 7.8-1

Application conditions, 7.3-1

Application range, 7.2-2

B

Basic insulation, 7.4-3

Baud rate, 7.4-4

- Selection, 7.5-3

C

Code numbers, Access via the fieldbus module, 7.6-47

Code numbers / index, Conversion, 7.6-47

Code table, DRIVECOM, 7.8-3

Codes

- Controller, 7.8-2

- Fieldbus module 2113, 7.8-1

- Lenze, 7.6-47

Commissioning, 7.5-1

- of the fieldbus module, 7.5-5

Communication medium, 7.3-1, 7.4-4

Components of the fieldbus module, 7.4-1

Configuration

- Process data channel, 7.6-2

- Process data,, 7.6-4

Connection

- from the INTERBUS, 7.4-6

- to the INTERBUS, 7.4-7

Control, DRIVECOM, 7.6-30

Control word, 7.6-3, 7.6-36

- 8200 vector, 7.6-14

- 82XX, 7.6-10

- 93XX, 7.6-19

Controller, Process data signals, 7.6-7

Conversion formula, Lenze codes, 7.6-47

CRL entries, 7.6-49

Cycle time, 7.3-4

D

Data transfer, 7.6-1

Default setting

- of the DIP switches, 7.5-2

- Subindex 6000, 7.6-5

- subindex 6001, 7.6-6

Device control, 7.6-28

Device control AIF-CTRL, , 7.5-3

Dimensions, 7.3-6

DRIVECOM

- Control word, 7.6-36

- Enable controller, 7.5-7

- Error code, 7.7-5

- Monitoring parameter, 7.6-34

- Parameters of the DRIVECOM profile, 7.6-33

- Process data description, 7.6-33

- Ramps, 7.6-44

- Speed / velocity channel, 7.6-42

- Status word, 7.6-39

DRIVECOM control, Control, 7.6-30

DRIVECOM compatibility, 7.5-8

DRIVECOM control, , 7.5-3

DRIVECOM control word, Assembly, 7.6-37

DRIVECOM status word, Assembly, 7.6-40

E

Electrical installation , 7.4-3

Error code, 7.6-35

- Index 603F, 7.6-35

F

Features, 7.2-2

Fieldbus module 2111 INTERBUS, Matching settings, 7.5-5

Frequency setpoint, 7.6-3

G

General data, 7.3-1

General information, 7.2-1

Get-OV, 7.6-51

H

Hardware version, Type code, 7.2-1

I

Identification, 7.2-1, 7.6-51

Identify, 7.6-51

Index, 7.9-1

- Conversion, 7.6-47

Initiate, 7.6-50

Installation, 7.4-1

- Wiring to the host, 7.4-3

INTERBUS cycle time, 7.3-4

INTERBUS master, Possible settings, 7.5-4

INTERBUS process data length, 7.8-1

L

Lenze codes, 7.6-47

- Conversion formula, 7.6-47

- Name, 7.6-47

Lenze data types, 7.6-47

M

Mains isolation, 7.4-3

Mechanical installation, 7.4-2

Monitoring parameter, 7.6-34

Monitoring time, Index 6003, 7.6-34

N

Network topology, Point-to-point, 7.4-4

P

Parameter data, 7.6-1

Parameter data channel, configuration, 7.6-47

Parameter data words, 7.5-3, 7.8-1

Parameter sets, 7.6-48

- Lenze, 7.6-48

Parameters

- Control word (C0135), 7.6-3

- DRIVECOM profile parameters, 7.6-33

- Frequency setpoint (C0046), 7.6-3

PCP communication, initialisation, 7.6-49

PCP services, 7.6-49

- Abort, 7.6-50

- Get-OV, 7.6-51

- Identify, 7.6-51

- initiate, 7.6-50

- Read and write, 7.6-50

- Status, 7.6-52

PI, 7.6-2

PI data, Index 6000, 7.6-5, 7.6-33

PI/PO data configuration, Examples, 7.6-26

PO, 7.6-2

PO data description, Index 6001, 7.6-6, 7.6-33

Preparations, for drive control using the INTERBUS, 7.5-6

Process data channel, configuration, 7.6-2

Process data description, 7.6-33

Process data monitoring time, 7.6-34

Process data preconfiguration, Parameter values, 7.8-4

Process data signals, 7.6-7

- 8200 vector, 7.6-11

- 82XX, 7.6-7

- 9300 Servo PLC, 7.6-20

- 93XX, 7.6-15

- Drive PLC, 7.6-20

Process data telegram

- from the controller, 7.6-7

- to the controller, 7.6-9

Process data transfer, 7.6-2

Process data words, 7.5-2

Process data,, 7.6-1

- configuration, 7.6-4

- Preconfiguration through L-C0009, 7.6-24

- Proconfiguration, 7.8-4

Process-data configuration, 7.6-24

Process-data structure, 7.6-4, 7.6-24

Processing time

- in the controller, 7.3-5

- in Drive PLC, 7.3-5

Proconfiguration, of process data, 7.6-24

Protocol data, 7.3-3

R

Ramps, 7.6-44

Rated data, 7.3-2

Read and write, 7.6-50

Index

S

Services, PCP, 7.6-49

Setpoint source, 7.6-3

Settings

- with INTERBUS master, 7.5-4

- with the front switch, 7.5-2

Software version, Type code, 7.2-1

Speed / velocity channel, 7.6-42

Status, 7.6-52

Status word, 7.6-39

- 93XX, 7.6-17

Switch, Possible settings, 7.5-2

Switch position, 7.8-1

System bus (CAN), Technical data, Communication times, 7.3-4

T

Technical data, 7.3-1

TRIP, Error reset, 7.7-4

Troubleshooting, 7.7-1

Type code, 7.2-1

V

Value range, 7.6-47

W

Wiring, to a host, 7.4-3

